

Perlick®



Perlick®



This Perlick Draught Beer Reference Manual is designed to support distributors, retailers, and third party service/installation companies/individuals in achieving a consistent and highest quality of the draught in the market.

This manual is designed to be an in-field “How To” reference guide that gives basics of the installation, troubleshooting and servicing of draught beer at retail.

Each brewer goes to extreme lengths to ensure the quality of their draught beer products. By following the materials laid out in this manual, you will be able to:

- Maintain the quality integrity of the brands of draught beer that you present.
- Ensure that the draught beer products that you carry are drawn properly.
- The quality of the beer that is built into each batch of draught beer is passed down to the customer.

Perlick (as a supplier of draught beer dispensing equipment, parts and industry expertise) expresses its deep appreciation of the Brewers Association for allowing us to use its Brewer Association- draught beer quality manual as a reference source for this manual.

We support the Brewers Association in being a base source of knowledge that can be accessed by the industry to support the sale, service and installation of draught beer in the industry.

Brewers Association
736 Pearl Street
Boulder, CO 80302
303.447.0816 • 888.822.6273
info@brewersassociation.org • www.draughtquality.org

Brewers Association
www.beertown.org





Table of Contents

| | | | |
|--|----|---|-----|
| Preface | 1 | Systems resistance | 60 |
| History of Perlick | 4 | Determining applied gauge pressure..... | 64 |
| Anatomy of Beer | 6 | Out of balance systems | |
| Section 3: Draught Beer Basics | | Over-restrictance | 66 |
| Draught beer basics | 8 | Under-restrictance..... | 66 |
| Keg sizes..... | 9 | Special balancing scenarios | 67 |
| Keg tapping procedures..... | 11 | Section 9: Special Events | |
| Draught beer care and handling | 13 | Picnic pumps or party taps | 72 |
| Section 4: Draught Beer Systems | | Tapping the keg..... | 72 |
| Draught beer basics | 16 | Jockey boxes..... | 73 |
| Air-cooled dispensing system..... | 17 | Cleaning and maintenance..... | 74 |
| Refrigerated line systems | | Planning a party | 74 |
| Glycol systems..... | 19 | Section 10: Troubleshooting | |
| Section 5: Building a Draught System | | Troubleshooting process | 76 |
| Refrigeration/cooling..... | 24 | Problem beer descriptions/causes | 76 |
| Basics of building the beer line | 24 | Troubleshooting a refrigerated system | 77 |
| Couplers | 24 | Section 11: Sanitation | |
| Coupler troubleshooting | 28 | Sanitation | 80 |
| Beer line..... | 29 | Cleaning standards | 80 |
| Installing the beer line connector | 30 | System design and cleanliness..... | 80 |
| Connecting the beer line to the coupler | 31 | System maintenance | 81 |
| Faucet standards..... | 32 | Cleaning frequency | 81 |
| Faucet assembly/disassembly | | Cleaning solutions..... | 82 |
| Standard faucet | 35 | Cleaning methods | |
| Ventless faucet | 36 | Recirculation by electric pump | 83 |
| Faucet troubleshooting | 37 | Static pressure cleaning pot..... | 85 |
| Completing the beer system | 38 | Beer line replacement guidelines | 87 |
| Section 6: Carbon Dioxide/Nitrogen | | Section 12: Serving Draught Beer | |
| Carbon Dioxide..... | 40 | Serving draught beer | 90 |
| Nitrogen | 41 | Sinks | |
| Under/over carbonated beer | 42 | Three-tank sinks..... | 90 |
| Care and handling of CO ₂ | 42 | Four-tank sinks | 91 |
| Primary regulators | 43 | Electric brushes | 92 |
| Nitrogen regulators | 45 | Glass washing machines..... | 92 |
| Secondary regulators..... | 46 | Testing for "beer clean" glass..... | 92 |
| Safety relief valves..... | 46 | Care and handling of glassware..... | 93 |
| Testing primary/secondary regulators | 47 | Beer and glassware serving temperatures | 94 |
| Troubleshooting regulators..... | 48 | Proper draught beer pouring techniques | 94 |
| Changing CO ₂ tanks..... | 49 | Section 13: Appendix | |
| CO ₂ lines | 50 | A..... | 98 |
| Perlick CO ₂ and Nitrogen accessories | 50 | B..... | 99 |
| Section 7: System Enhancements | | C..... | 100 |
| Draught beer system enhancements | 52 | D..... | 102 |
| Kegs in a series | 53 | E..... | 103 |
| Keg series components..... | 54 | F..... | 105 |
| Section 8: Systems Balancing | | G..... | 106 |
| System balancing..... | 58 | Section 14: Glossary | 108 |
| Applied gauge pressure | 58 | | |

A HISTORY OF EXCELLENCE IN BEER

“ Build the best product you can. A poorly made product is expensive at any price. Do not listen to those who would have you build something cheaply. Be honest with yourself, your customers and your fellow man. Only a few black marks will soil a good name and reputation. Remember these things always.”

— Robert Perlick, 1925

Since its inception in 1917, the Perlick Corporation has evolved into the premier supplier of Bar and Beverage Dispensing equipment in the industry. Perlick equipment can be found in restaurants, hotels, stadiums, theme parks, breweries and the finest homes worldwide. Headquartered in a 300,000-square-foot manufacturing facility in Milwaukee, Wisconsin, Perlick prides itself on manufacturing high quality, American-made products.

Perlick's Commercial Products include Bar and Beverage Equipment, Tapping Equipment and Brewery Fittings. The Bar and Beverage group manufactures equipment used in the bar environment to include remote beer systems, refrigerated and non-refrigerated cabinets, stainless steel underbar equipment glasswashers and the revolutionary modular bar structure which completes the bar package. Perlick's Tapping group manufactures beer faucets, keg couplers and other beer dispensing components. The Brewery Fittings division is responsible for stainless steel and brass fittings which are used in the brewing process.

Perlick's expertise in the beer industry spans decades, from their first sale of a remote glycol beer system in the late 1950's to today, where a Perlick system can dispense the perfect beer up to 1,000 feet from the keg to the dispensing tower. Over the years, Perlick has worked closely with all the major breweries to ensure that the consumer is getting a brewery fresh beer dispensed through a Perlick system each and every pour.

TIMELINE



January 1, 1917 – Robert Perlick and his son Walter open the doors of R. Perlick Brass Works

February 14, 1920 – R. Perlick Brass Co. is incorporated

1921 – Perlick introduces its first product - Battery terminal

1922 – Perlick introduces its second product - Window anti-rattlers for automobiles.

1925 – Perlick adds keg fittings to its product offering per the direction of newly hired Fred Seidlitz

Circa 1933 (early post-Prohibition years) – Perlick adds a refrigeration department to aid in transition of cooler boxes cooled with ice to mechanical refrigeration.

1962 – Century Beer System is introduced. Century was the first glycol beer system that could transport beer 100 feet.

1963 – The Perlick Corporation moved to the newly-constructed 300,000-square-foot manufacturing and office facility on Milwaukee's far northwestside at 83rd and Good Hope Rd.

1964 – Perlick adds Flavor King Soda System to its expanding product offering. Flavor-King was a glycol-cooled soda system in which Perlick utilized the Flavor King power pack for both soda and beer.

2002 – Perlick redesigns the Century Beer System to go up to 1,000 feet, which allows more design flexibility for stadium projects.

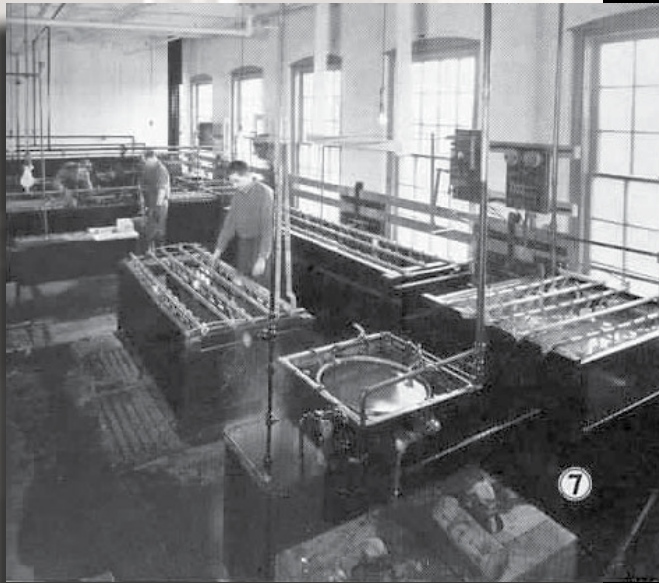

underbar
DIRECT DRAW
BEER
DISPENSERS
by **Perlick**

CATALOG NO. 400

Anatomy of BEER

Alcohol Content Beer ranges from less than 3% to just under 30% alcohol by volume.

Carbonation Carbon Dioxide is a by-product of fermentation.



Aroma Determined by malt, grain and fermentation by-products.

Head Produced by bubbles of carbon dioxide rising to the surface.

Color Determined by the kilning of the malts. Can also depend on mashing, boiling and fermentation.

Flavor Determined by the malt, hops and water used in the brewing process.

Ale

Beer that is fermented more quickly and at warmer temperatures, with top-fermenting yeast.

Amber

A beer named for its reddish-brown color, ranging from pale to dark.

Bock

A strong, dark German beer brewed for spring.

Brown Ale

Nutty, malty ale that's dark brown in color with flavors ranging from dry to sweet.

Hefeweizen

"Yeast wheat" in German; an unfiltered wheat beer that is bottle conditioned and cloudy when served.

Imperial Stout

A strong, hoppy black ale that originated in Britain for export to Czarist Russia (also referred to as "Russian Stout").

India Pale Ale

A strong, hoppy pale ale that originated in Britain for export to soldiers in India.

Lager

Beer fermented more slowly and at cooler temperatures than ale, with bottom-fermenting yeast, and which is then aged for a smooth, clean flavor and aroma.

Pale Ale

A mild version of India Pale Ale, only fruitier.

Pilsner

A general name for pale, golden-hued, highly hopped, bottom-fermented beers. The original was first brewed in the Bohemian town of Pilsen in 1842.

Porter

Ale brewed from well-roasted barley. Dark brown in color, full-bodied in texture, and bittersweet or chocolaty in flavor.

Stout

An English- and Irish-style ale that is opaque black, smooth and creamy. It may be dry or sweet.

Vienna

A German-style lager that is sweet, malty and reddish in color. It was originally brewed in Vienna.

Weizenbier

"Wheat beer" in German; an ale that is brewed with between 20 and 60 percent wheat that is usually served in the summer.



Section 3

Draught Beer Basics



3



Draught Beer Basics

Draught beer represents each brewer's finest form of each of their brands of beer and is regarded as the package that tastes closest to brewery fresh. To this point, special care goes into the packaging, distribution and serving of draught beer at all levels of distribution.

The Importance of Draught Beer

Although draught beer is about 10% of total United States sales, it is of vital importance to all three levels of the beer distribution system: brewery, distributor and retailer. The following is a list of benefits for each level of distribution.



Brewery

- Brewer's pride
- Brand awareness
- Sampling device
- Stimulates package sales
- Draught beer sales are approximately 10% of total beer sales



Retailer

- Easy to handle
- Draught beer enjoys steady sales in all four seasons (less than a 3% variation)
- Increases sales of other high-volume, high-profit, tie-in items
- Less waste
- Unique to on-premise sale
- Highly profitable
- Green — No package disposal
- Less handling loading coolers with bottles and cans
- Distributor removes kegs from location.

Distributor

- Brand awareness
- Sampling device
- Stimulates package sales
- On-premise distribution



The Keg

Kegs enable beer transport and dispensing while, at the same time, maintaining the quality and integrity of the beer. Its design protects beer from both air and light while enabling easy and rapid dispense. Most brewers use kegs made of stainless steel, but you also see rubber-coated, aluminum, steel and recently plastic kegs in the marketplace.

Keg Sizes

In the U.S. beer is measured in barrels, a barrel (Fig. 3.1) being 31 U.S. gallons. The charts below show the different sized domestic and import kegs.

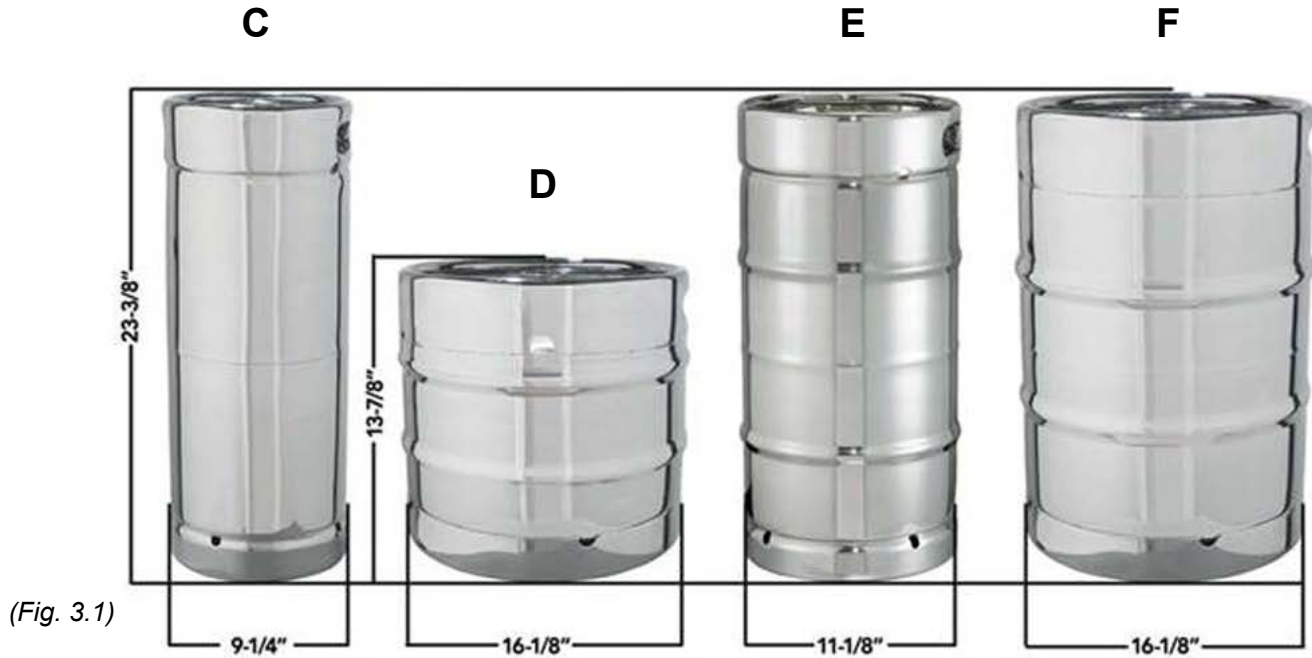

| | (A) | (B) | (C) | (D) | (E) | (F) |
|----------------------------|-------------------|-----------------|-------------------|-------------------|------------------------|-------------------|
| Keg | 1/8 Barrel | 5 Gallon | 1/6 Barrel | 1/4 Barrel | Slim 1/4 Barrel | 1/2 Barrel |
| Gallons | 3.88 | 5 | 5.16 | 7.75 | 7.75 | 15.5 |
| Ounces | 496 | 640 | 661.3 | 992 | 992 | 1984 |
| # of 12 oz. beers | 52 | 67 | 69 | 103 | 103 | 207 |
| = # of 12 oz. cases | 1.699 | 2.199 | 2.280 | 3.433 | 3.433 | 6.889 |

Some imported beers come in one of two sizes of kegs:

| Keg | European | European |
|--------------------------|-----------------|-----------------|
| Gallons | 13.2 | 13.5 |
| Ounces | 1,690 | 1,728 |
| # of 12-oz. beers | 176 | 180 |
| Approx. Liters | 50 | 51.1 |
| # of 12-oz. cases | 5.768 | 6.000 |



The Anatomy of a Sankey Keg (Fig. 3.2)

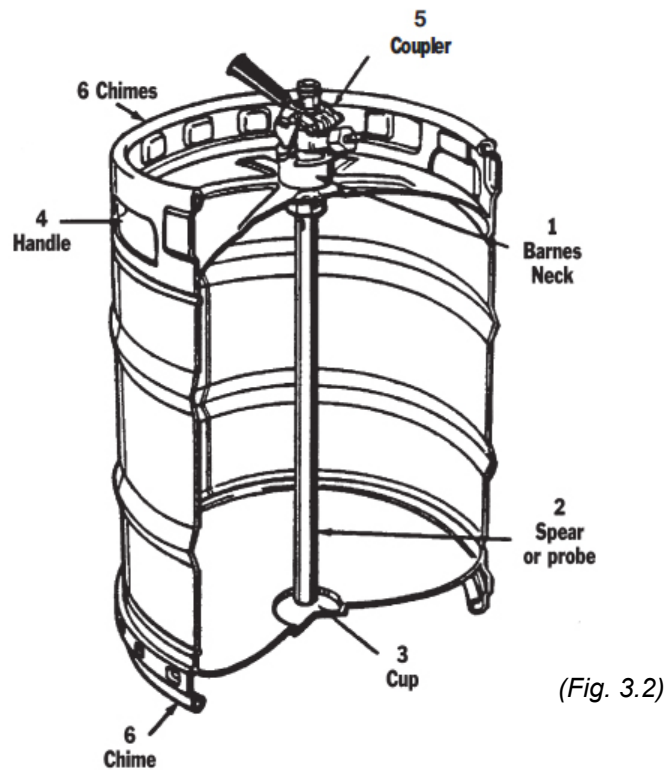

1. **Barnes neck (1)**

The neck at the top of the keg into which you insert the coupler. This is the only opening in the keg, eliminating the possibility of foreign objects getting inside the keg.

2. **Spear aka Probe aka Draw Tube (2)**

A hollow stainless steel tube inside the keg that goes to within 3/16" of the bottom of the keg when tapped. Beer flows up the tube and out of the keg.

3. **Sankey cup (3)**

A "hollow" dish at the base of the keg. Beer collects in the cup, which allows us to extract virtually all the beer from the keg.

4. **Handle (4)**

A cutout portion in each side of the keg's top chime (6). *Note: Always lift the keg by the handles.*

5. **Coupler (5)**

Used to insert into the Barnes neck (1) to tap the keg.

6. **Top Chime (6) and Bottom Chime (7)**

Rim at the top and bottom of keg. This is the weakest part of the keg, and will bend if dropped on hard surface. To ensure stacking capabilities and prevent costly maintenance, a keg bumper must be used when unloading to cushion the shock and prevent costly damage.



Keg Tapping Procedures

Single Handle Coupler

Tapping procedure is as easy as 1-2-3.

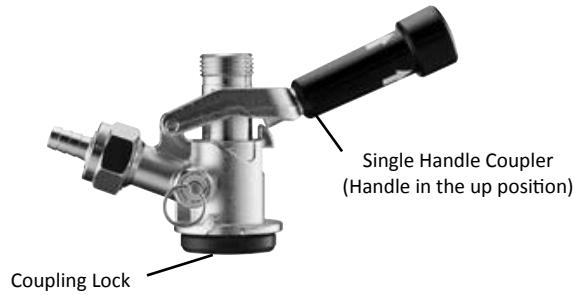

1. Place the coupler tapping handle in the up position. Pull tapping handle out away from the coupler body and lift up. Now align the coupler lug locks with the keg lug lock slots, in the tapping well on the top of the keg, and insert coupler.

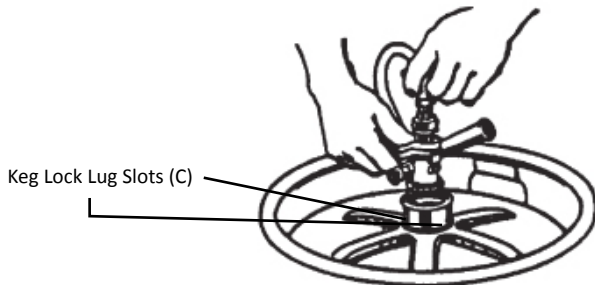

2. Turn coupler a 1/4 turn clockwise securing the coupler to the keg.

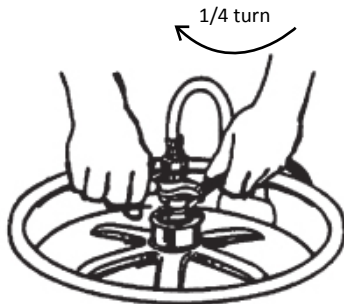

3. Pull the tapping handle up and out away from the coupler body, then push handle down to the end of its travel and then push the handle back in towards the coupler body. This will open the keg's beer and CO₂ valves. The keg is now tapped.

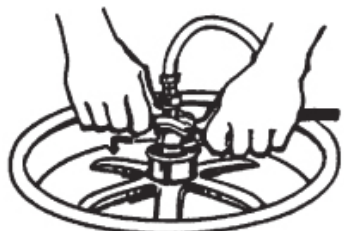

"T" Handle Coupler

Tapping procedure is as easy as 1-2-3.

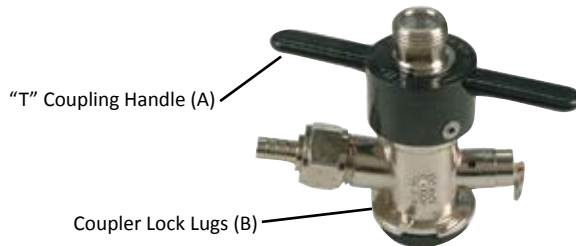

1. Grab the coupler body in one hand and then turn the "T" handle counterclockwise to assure that the coupler is in the off position. Align the coupler lug locks with the keg lug lock slots, in the tapping well on the top of the keg and insert coupler.

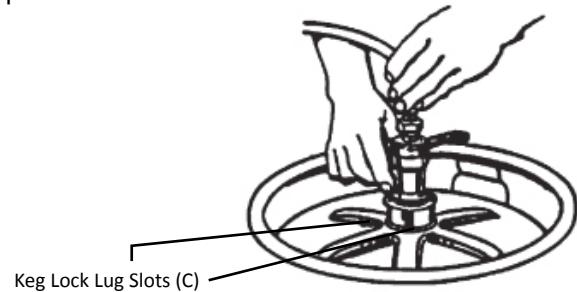

2. Grab the coupler body (not the "T" handle) and turn the coupler body a 1/4 turn clockwise; the coupler is now secured to the keg..

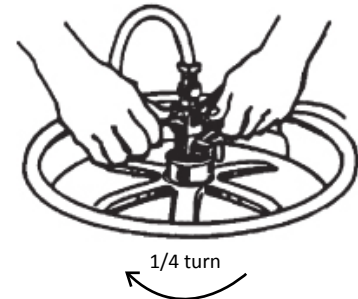

3. Now turn the tapping "T" handle a 1/4 turn clockwise to open the beer and CO₂ ports in keg. The keg is now tapped.

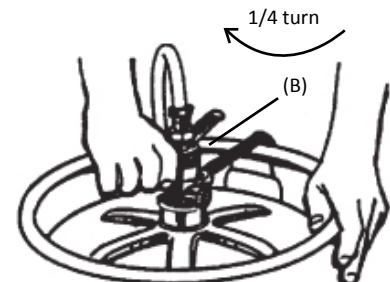

How the Beer is Drawn out of the Sankey Style Keg

With either the single handle or “T” handle coupler, the beer is drawn from the keg as pictured below using the single handled coupler in this example:

Single Handle Coupler



“T” Handle Coupler

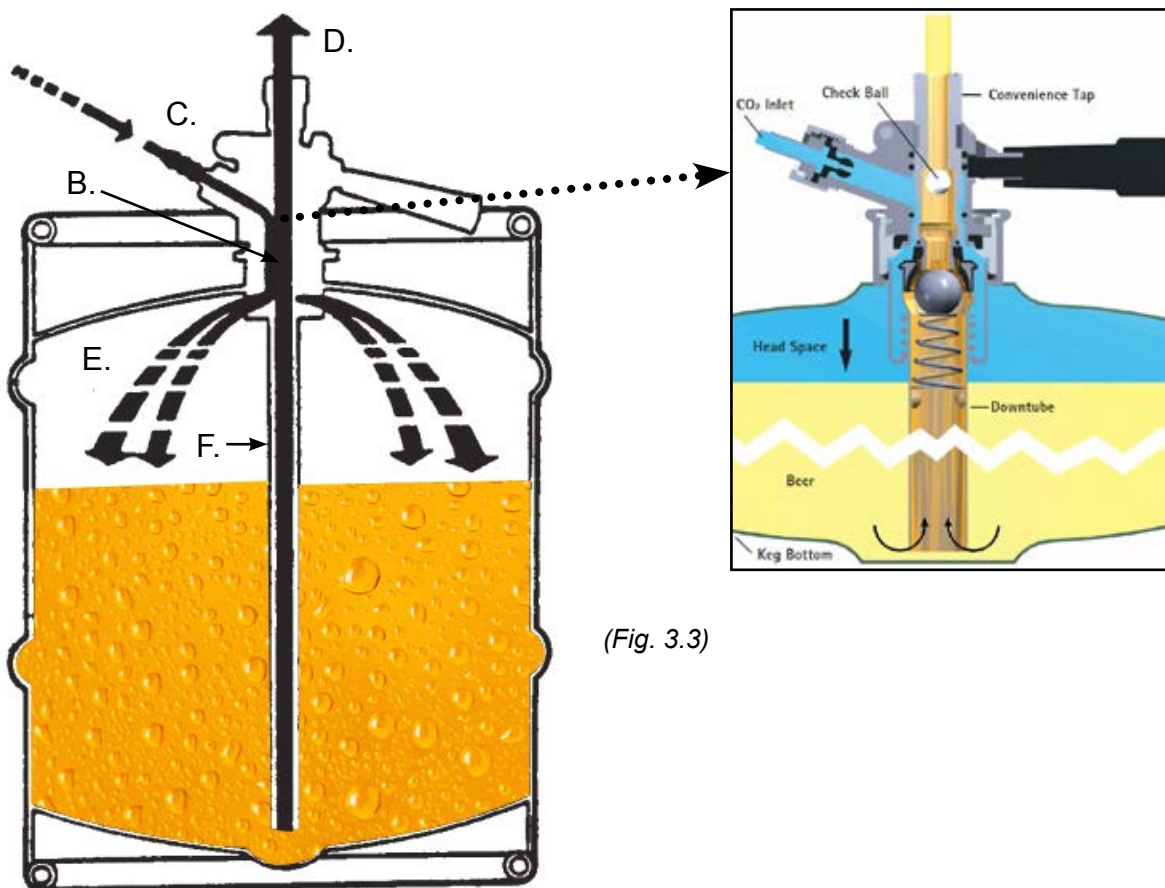

(Fig. 3.3)

In Fig. 3.3, the coupler (A) has the CO₂ gas line attached to its CO₂ inlet (C). The beer line is attached to the top of the coupler probe (D). When the coupler is attached to the keg tapping well (B) and tapped, the CO₂ passes through the CO₂ inlet (C) and into the keg between the inside of the coupler body (A) and the outside of coupler probe (D).

The CO₂ gas (E) pushes down on the top of the beer in the keg's head space. This forces the beer to go up the inside of the draw tube (F), through the inside of the probe (D) and out of the keg and into the beer line.



Draught Beer Care and Handling

Receiving and Storing Draught Beer at the Distributor's Warehouse

- When draught beer arrives it should be immediately transferred to the cooler and stored at a temperature of 32° to 38° F.
- The kegs should be held in storage for a minimum of two days before delivering to the retail trade.
 - The two-day holding period allows the beer time to settle and attain the proper temperature for delivery.
 - An accurate thermometer (placed in water) should be strategically located in the cooler to ensure it is at the proper temperature.
 - Check the temperature twice daily (morning and evening) to ensure proper cooler temperature.
- All kegs, full or empty, must be handled with care to avoid damage to the container or product.
 - Rope or rubber bumpers should be used to break the fall when unloading full kegs from delivery vehicle.



- Each shipment received should be rotated to ensure that the oldest draught beer will be used first.
- A draught beer cooler temperature record should be filled out daily.

Cooling and Warm Up Time

Time it takes to cool the beer from start temp to 38° F in a 36° F cooler.

If a keg is left at room temperature it will warm up over time as follows:

| Start Temp | Hours | Hours at Room Temp | Temp |
|------------|-------|--------------------|-------|
| 50° F | 25 | 0 | 38° F |
| 48° F | 23.5 | 1 | 39° F |
| 46° F | 21 | 2 | 41° F |
| 44° F | 18 | 3 | 42° F |
| 42° F | 13.5 | 4 | 43° F |
| 40° F | 7 | 5 | 45° F |
| 38° F | 0 | 6 | 48° F |

Delivery and Return of Kegs

- Ideally the last keg delivered should be as cold as the first.
 - A refrigerated truck ensures this kind of delivery. If volume does not warrant a refrigerated truck, a closed insulated truck should be used. The kegs can be kept cold by covering them with an insulated blanket.
 - During hot months, non-refrigerated trucks should return to the warehouse and exchange warm kegs for cold ones. The warm ones should be put back in the cooler and cooled down to the proper temperature prior to delivery.
- Empty kegs must be properly collected from the retail trade and stored in a protected area until they are returned to the brewery.
 - Prompt return of empty kegs to the brewery will ensure a smooth flow of product to the trade.

Use of Bumpers

When taking full kegs off a truck, a keg bumper should be used (below). This prevents chime damage (top and bottom). Chime damage costs the brewers and the distributors tens of thousands of dollars each year to repair damaged kegs that were not properly delivered using keg bumpers. Thus, the use of keg bumpers is an important part of quality control and quality image of draught beer.



Section Summary

To make the beer draw properly, it is essential that additional core components of a draught beer system are in place. The other core components listed below will be discussed in the next few chapters of this manual:

- The refrigeration/cooling components of the beer in the keg and the beer line up to the faucet.
- The gases used to push the beer through the system — CO₂, Nitrogen and CO₂/Nitrogen blend.
- The gas parts, beer line parts and accessories needed to build the beer line and transport the beer to the faucet.
- The proper balance of the temperature and pressure in the system to assure a trouble-free pour of each glass of draught beer.
- The proper care and sanitation of the draught beer system to assure not only a trouble free pour but also maintain the integrity of the product.





Section 4

Draught Beer Systems



4



Draught Beer Systems

The main function of a draught beer system is to move the beer from the keg to the faucet in the least amount of time.

- Over the shortest distance
- Without damaging the product

There are Two Types of Draught Beer Systems:

1. Air-Cooled Systems
2. Refrigerated Line Systems

Air Cooled Systems

Air-cooled systems are defined as any system that uses circulating cold air to keep the beer cool in the cooler, around the beer lines and up to the faucet.

Air-cooled systems can be divided into two sub categories:

- A. Direct Draw Systems
- B. Remote Forced Air Systems

A. Direct Draw Systems (Fig. 4.1 and 4.2)

A direct draw system is any self-contained refrigerated unit:

- To which the faucet is directly attached
- In which the keg is stored, cooled and tapped
- The beer in the keg, beer line and tower to which the faucet is attached is cooled by circulated cold air.

B. Remote Forced Air System (Fig. 4.3 and 4.4)

A remote forced-air system is any system where:

- The beer is stored, cooled and tapped in a cooler
- The beer is transported to the faucet at remote location from the cooler
- The beer in the keg, beer line and exchange box to which the faucet is attached is cooled by circulated cold air.

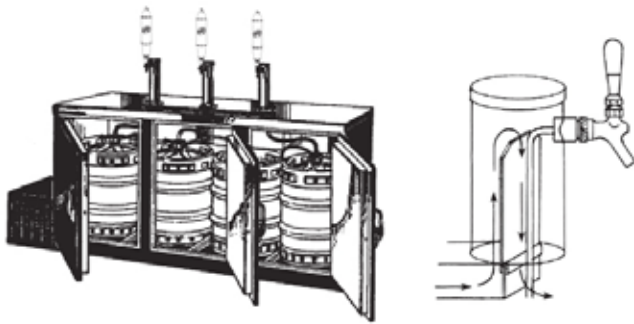

Direct Draw from a Keg Box (Fig. 4.1)

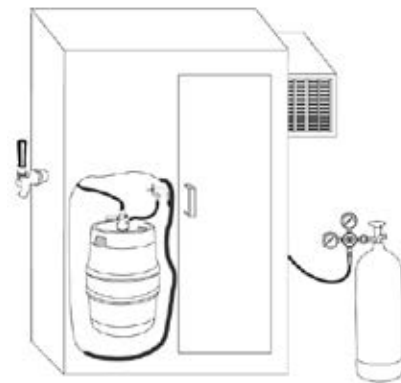

Direct Draw from a Walk-in Cooler (Fig. 4.2)



The Remote Forced-air System circulates cold air from the cooler to the faucet using one of the following two methods:

Dual Duct System (Fig. 4.3)

The beer lines are housed inside a 4-in. flexible tubing, which is connected to the cooler at one end and the air exchange box at the other end. A blower mounted on the ceiling of the walk-in cooler (approximately 6-in. from the cooling unit) forces cold air through the tube to the exchange box behind the faucet keeping the beer lines cold. Once the air has reached the air exchange box, it returns to the cooler through the other 4-in. tube.

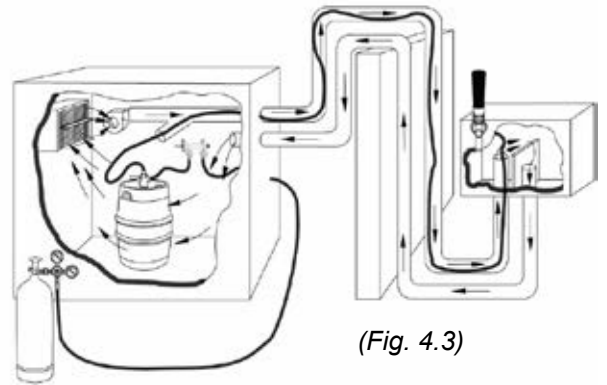

Single Duct System (Fig. 4.4)

The beer lines are housed inside a 3-in. flexible tubing which is contained within an insulated 4-in. flexible metal tubing that is connected to the cooler at one end and the air exchange box at the other end. A blower mounted on the ceiling of the walk-in cooler (approximately 6-in. from the cooling unit) forces cold air through the 3-in. tube to the exchange box behind the faucet keeping the beer lines cold. Once the air has reached air exchange box, it returns to the cooler through the larger 4-in. tube.

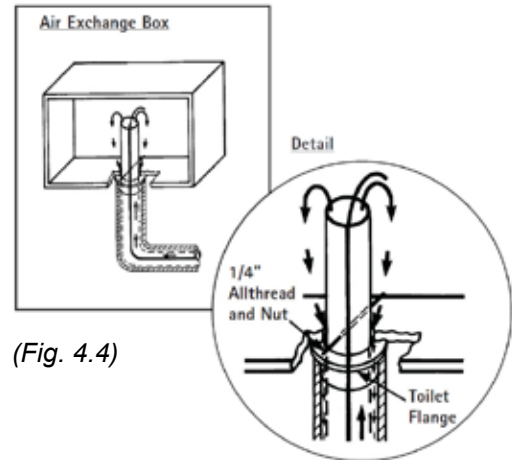

1) Air-Cooled Dispensing System

Forced Air Effective Length of Run

An air-cooled beer systems efficiency depends on temperature. It is important to use the cooler for beer storage only so that a consistent temperature of 34°F - 38°F can be maintained. The maximum recommended length is 25 ft. requiring 1,000 Btu per hour of additional refrigeration capacity. Forced air systems can be longer if there are only a few 90° bends in the system and the cooler is not frequently opened. Each 90° turn in the air tubing going to and from the faucet will result in lost cooling efficiency.

If the walk-in cooler is opened and closed frequently, this system will not work effectively because the air used to circulate through the system will warm up causing drawing problems.

Air System Parts/Flexible Tubing

For systems that are 6 ft. or less we have our “Thru-the-Wall Shafts” as follows:

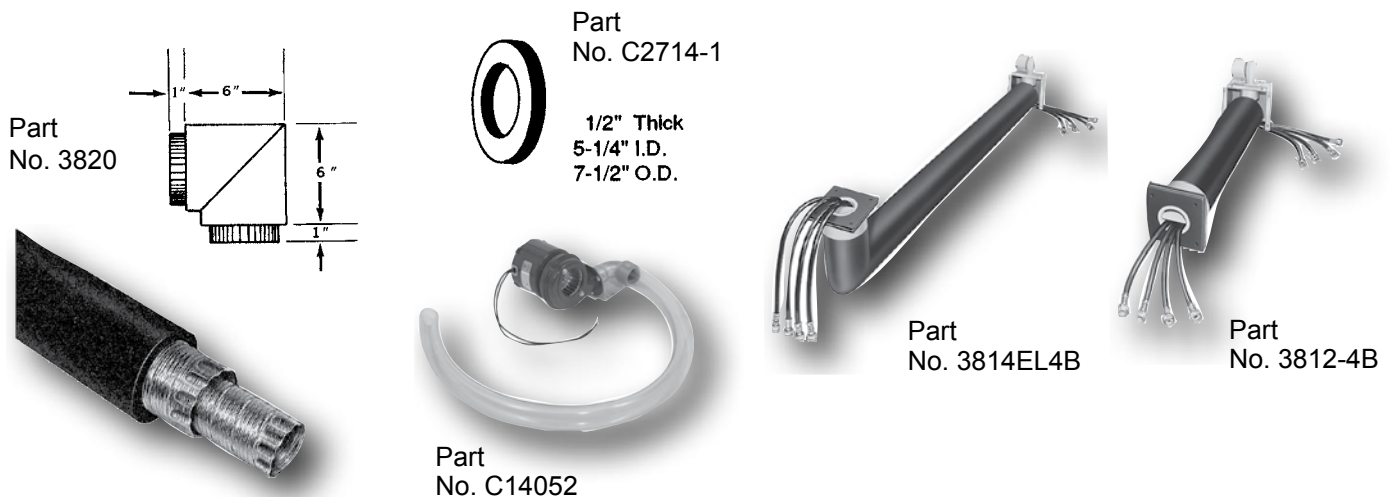

The following parts are available for the complete installation of Remote Forced-air Systems (Fig. 4.5):

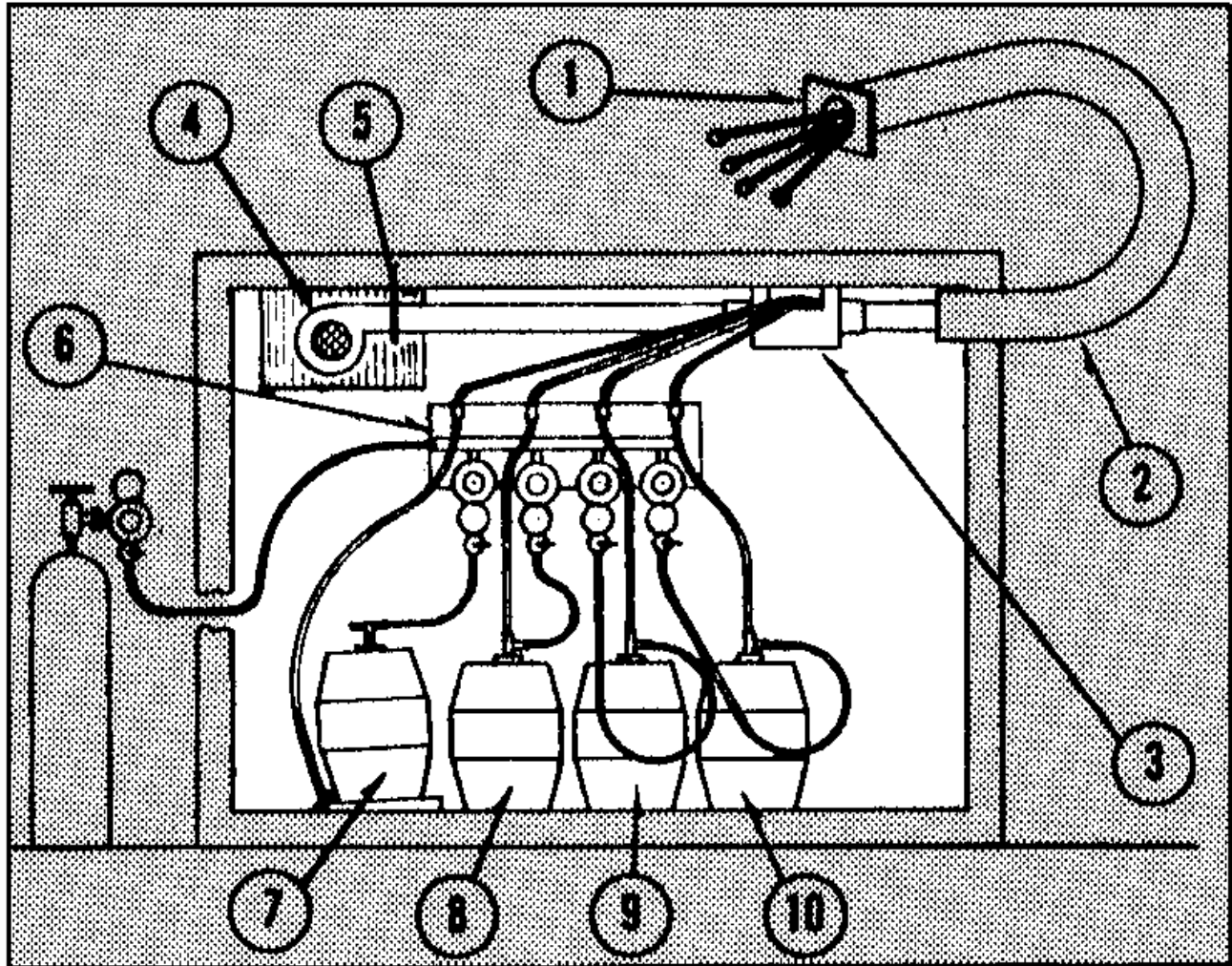

(Fig. 4.5)

1. Mounting collar for dispensing head
2. Dual duct air shaft
3. Wall-mounted air connector assembly
4. Blower
5. Blower hanger bracket (2 required)
6. Line coupler for 3-in. hose sections
7. Line coupler for 4½-in. outer hose section
8. 3-in. hose to duct air from cooler blower to dual hose air shaft
9. 3-in. hose adapter for blower
10. 90° elbow
11. Sealing gasket with adhesive back



2) Refrigerated Line Systems

We noted that air-cooled systems can be effective up to about 25 ft. if the air in the cooler can be kept cold.

In many cases we find that the bar area floor plan calls for the cooler to be in one location and the faucets in another, and at a distance of over 25 ft. In these cases, air-cooled systems are unreliable for maintaining the temperature of the beer. To allow beer to be dispensed at the ideal drawing temperature of 32°F to 38°F in systems over 25 feet in length, we recommend that you use a glycol system.

Glycol Systems

In a glycol refrigerated system (Fig. 4.6) the beer in the keg is kept cold by the cold air in the cooler, and the beer in the beer lines, dispensing tower and faucets is kept cold by the continual flow of glycol through the coolant lines.

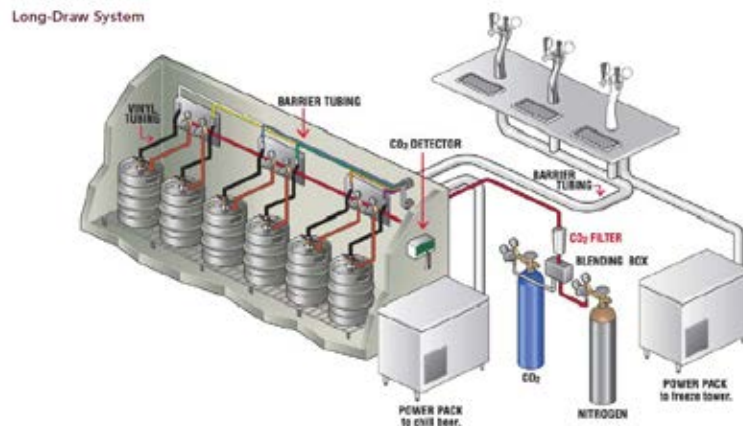

(Fig. 4.6)

In a glycol system the trunk housing (A) (Fig. 4.7) not only carries the beer lines (B), but it also carries two glycol cooling lines (C), made of copper or polyethylene to keep the beer in the beer lines cold. The lines are built at the factory where the beer lines and coolant lines are wrapped together, using a vapor barrier wrap (D).

Picture of the glycol line bundle with the beer lines and coolant lines.

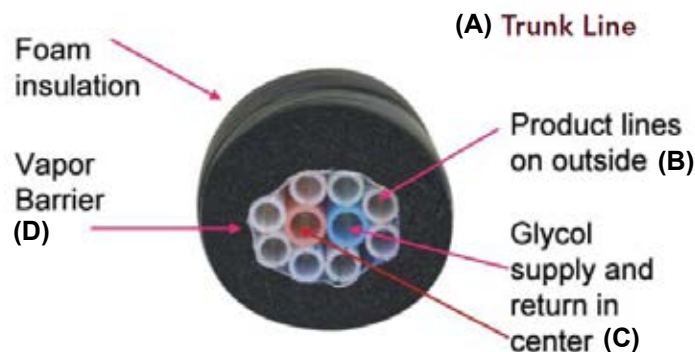

(Fig. 4.7)

Trunk Housing

The insulated housing/trunk line (A) consists of multiple polyethylene beer lines (B) which are taped securely to the coolant lines (C), so all the beer lines are in direct contact with the coolant lines the entire length of the trunk housing. Trunk housing lengths have been known to go up to 1,000 ft.



Glycol Power Pak

Picture of the glycol refrigerated system with an offset of the Power Pak (Fig. 4.8).

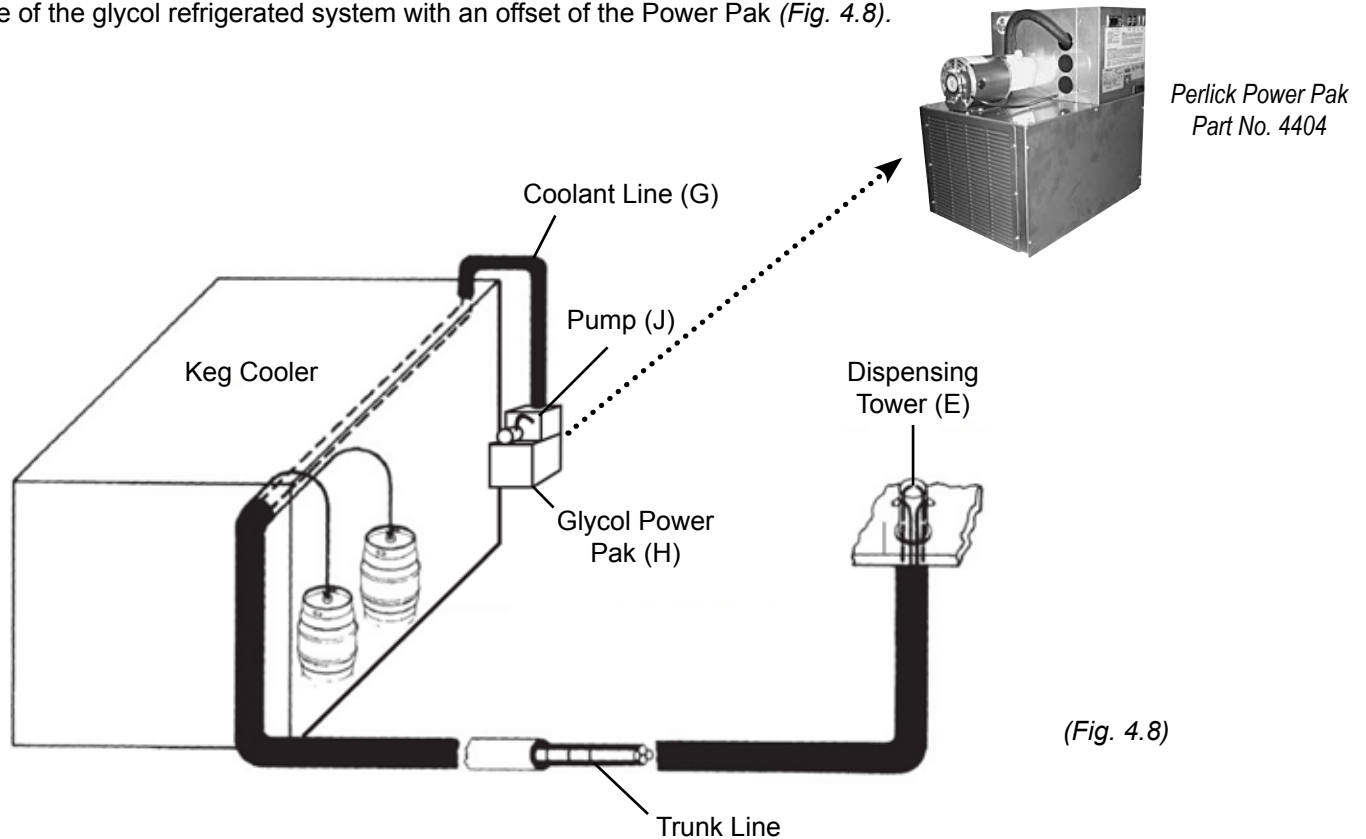

In the above picture, a pump (J) pushes the cold glycol out of the Glycol Power Pak (H) into the outgoing Glycol line through the trunk line, up through the tower (E) behind the faucets and returns to the Glycol Power Pak through the return glycol line. Here the returning glycol is re-cooled and continually pumped back through the system keeping the beer at its serving temperature.

The outgoing coolant line (G) is connected to a Glycol Power Pak (H, J). The sole purpose of the power pak is to refrigerate and circulate the glycol coolant from the walk-in cooler to the faucet shank and all the way back to the Power Pak for re-cooling. The coolant temperature is maintained between 28° and 34° F by an adjustable thermostat found on the Power Pak.

Perlick Century System

We offer our refrigerated system called the Perlick Century System. This system has been proven over and over in the market in over thousands of retail accounts, stadiums, arenas and chain accounts since it was introduced. It is tried and true and has evolved to be our current top-rated system. Each system is tailor-made to the needs of the account based on the number of stations to which the beer is being poured, number of products, length of run from the cooler to each station and the speed of draw required by the retailer.



Call 800-558-5592 for more information about the Century Beer System and its additional features such as its ability to add:

- Metered pour
- Nitrogen blenders or beer pumps — for extremely long draws and
- Custom beer towers.



Notes





Section 5

Building A Draught System



5



The Basics of Building a Draught Beer System

Refrigeration/Cooling

Consistent and controlled beer dispensing requires that the beer traveling from keg to glass is maintained at a consistent temperature of 30° to 38°F.

While temporary service (such as a keg in a keg jacket, special event and party equipment) may employ ice for cooling, most permanent installations employ refrigeration systems to keep the beer cold from the cooler, through the line and up to the beer faucet.

Cold box refrigeration systems can provide cooling for a small direct-draw box cooler or a large walk-in. It is the heart of the system, for without proper cooling the system will not work.

The refrigeration itself can either be self-contained with the compressor and condenser mounted on the unit or with a remotely mounted compressor and condenser.

Remotely mounting the compressor can benefit the installation by removing the source of heat from inside a room or building; however, this requires additional refrigerant piping and possibly higher costs.

Proper preventive care for compressor/condenser system is imperative; such as regularly cleaning of the condenser fins to prevent condenser fouling, which diminishes cooling capacity. Acid cleaning of the heat exchanger may be required to remedy condenser fouling.

Many draught system problems are revealed on the first hot day of the season due to a lack of preventive maintenance.

Once we can guarantee the temperature of the keg box or walk-in cooler we can proceed with the installation where legal. If it is not legal for you to install in your state, or you opt to use an outside installer, then make sure you have researched the draught beer installers in your market and can recommend quality installers to your retailer.

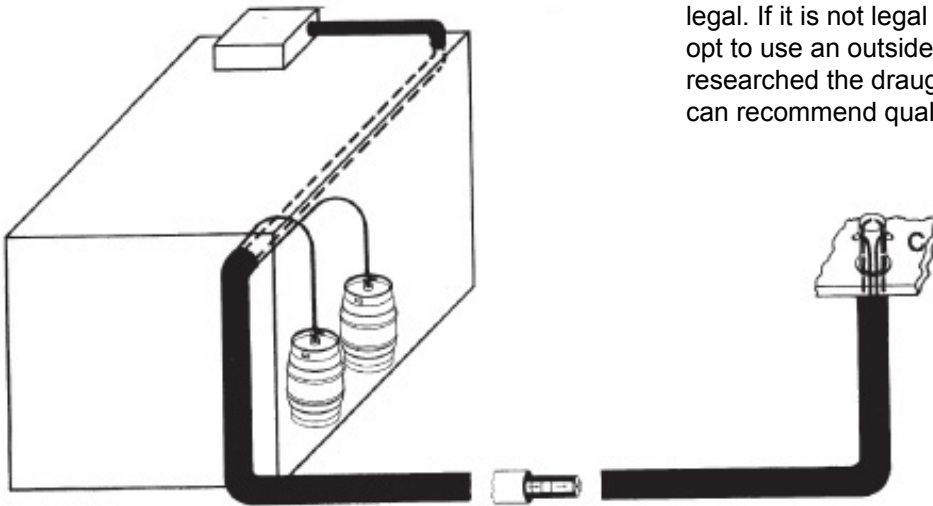

Basics of Building the Beer Line Couplers

The beer line side of a draught beer system starts with the coupler. As we have seen previously, there are two basic types of couplers in the market.

Let's take an up-close and personal look at how each tap is taken apart and reassembled and define the parts that make up each coupler.



Single Handle Coupler



"T" Handle Coupler



Single Handle Couplers

There are several manufacturers of Single Handle Couplers, each with their own slightly different design. We recommend the use of couplers that have the Bottom Seal Washer (F).

The following will give you general procedures that should apply to most manufacturers. For specific details of a specific brand of coupler, contact the manufacturer.

Procedures for Disassembly

1. Put coupler in the tapped position by pulling the tapping handle (A) up and out away from the coupler body (G); then push the handle down as far as it goes. Now push tapping handle back in toward the coupler body. You are now in the tapped position.
2. Remove the probe washer (C) using a bladed screwdriver to pry it off. Remove retaining screw (D) with the screwdriver.
3. Pull up on the tapping handle (A) to remove probe (E) and handle from coupler so you can inspect parts for replacements and lubrication.

Procedures for Reassembly

1. Set tapping handle (A) back into the probe slots (H) on probe (E).
2. Insert probe and coupler handle into coupler body.
3. Replace retaining screw (D).
4. Put tapping handle in tapped position and reinstall probe washer with tapered end up toward probe.

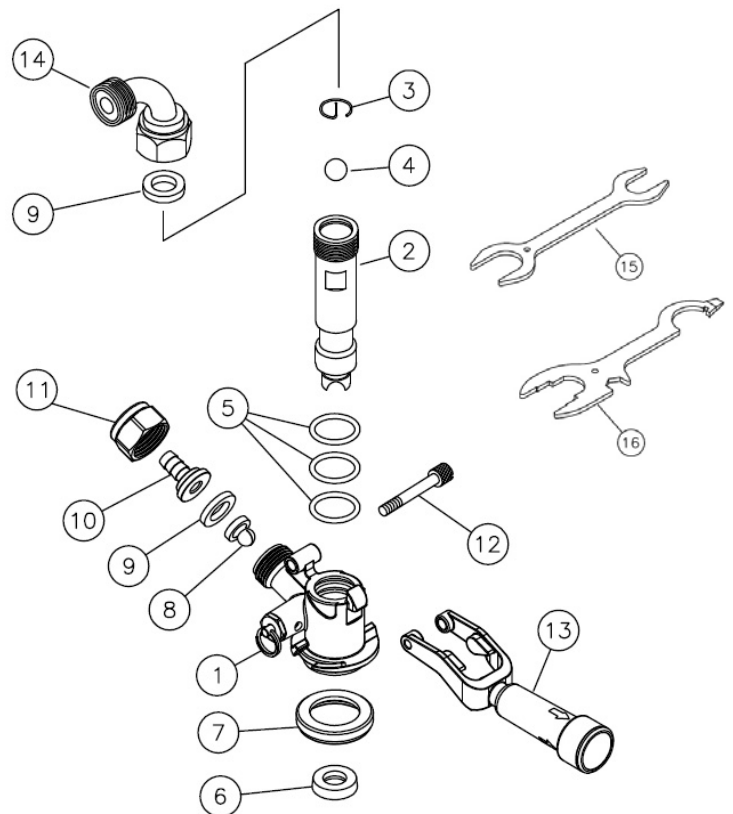
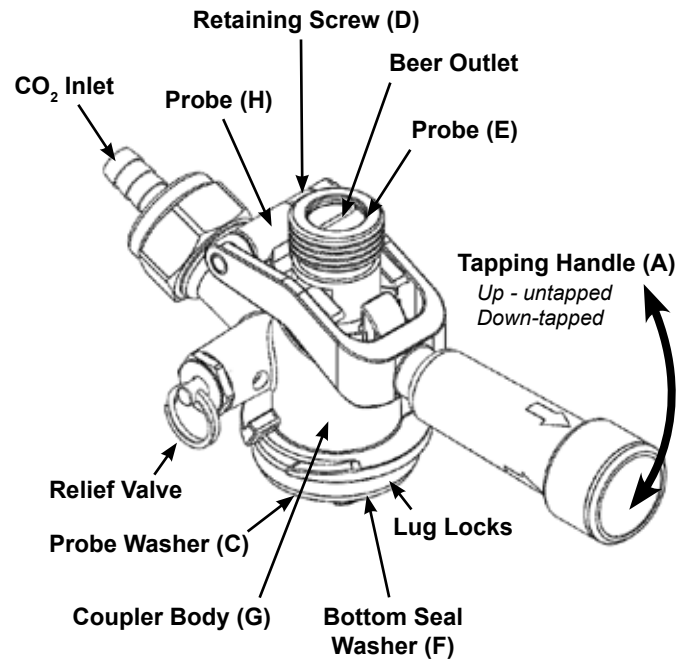

Single Handle Coupler Parts (Perlick Type)

| Item # | Part Number | Part Name |
|--------|-------------|-------------------------------|
| 1 | 65800 | Body |
| 2 | 40174-1SS | Probe—Domestic St. Sltl. |
| 3 | 43641-1 | Ball Stop |
| 4 | 31080-2P | Ball |
| 5 | 31089-2P | “O” Ring – 3-per Assembly |
| 6 | 31087-2P | Probe Washer – Domestic |
| 7 | 31088-2P | Bottom Seal Washer |
| 8 | 23682-2P | Check Valve |
| 9 | 157R2P | Washer |
| 10 | 2068-1 | Tail Piece |
| 11 | 2026 | Coupling Nut |
| 12 | 67045-1 | Retaining Screw |
| 13 | 67042 | Yoke Assembly |
| 14 | 2036SS | Elbow Coupling (optional) |
| 15 | 32474-1 | Wrench |
| 16 | 40106 | Combination Wrench (optional) |



“T” Handle Coupler

Procedures for Disassembly

1. In order to disassemble coupler, it is necessary to put the “T” Handle (A) in the tapped-in position by turning it clockwise.
2. Remove the probe washer (B) from the bottom of the Probe (D), by using a bladed screwdriver to pry it off.
3. Now holding the coupler body (C) in one hand push the “T” handle (A) down toward the bottom of coupler. While still depressed, turn the “T” handle counterclockwise to unlock the handle from coupler.
4. Now pull up on the “T” handle to remove handle and probe (D).
5. Now the probe can be inspected for parts lubrication and replacement if needed.

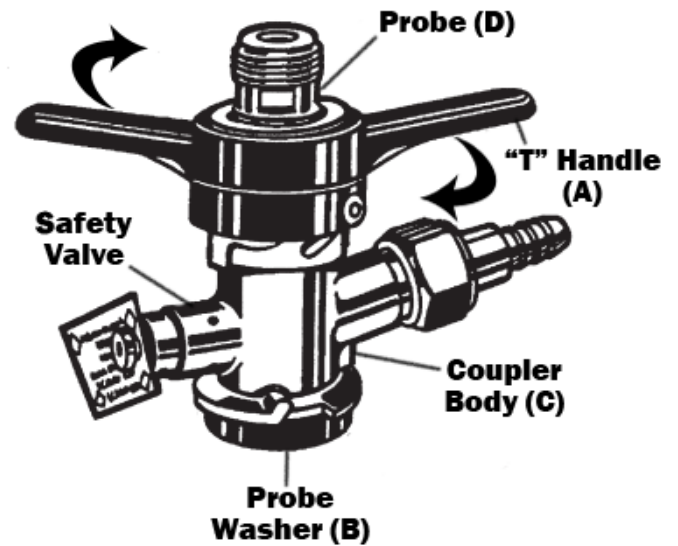

Procedures for Reassembly

1. Insert Probe (D) back into body.
2. Line up and push the “T” Handle in toward the bottom of the coupler and while still depressed turn the “T” clockwise to attach to coupler.
3. Now make sure “T” handle is in the tapped position by turning it clockwise.
4. Put the probe washer (B) back on the bottom of the probe.
5. Now turn the coupler back to the off position by turning the “T” handle counterclockwise.

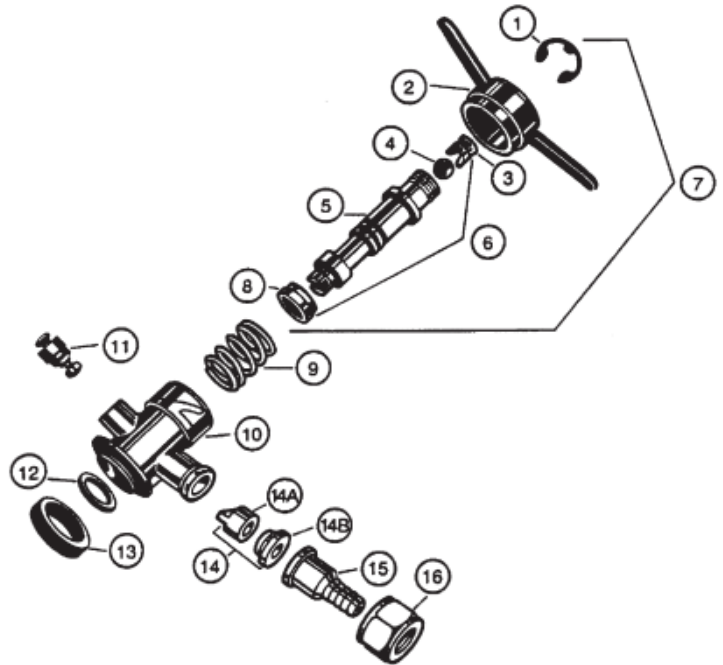

“T” Coupler Parts

| Item # | Part # | Part Name |
|--------|------------|---------------------------|
| 1 | FT85-114 | Handle retainer |
| 2 | FT85-8PA | Handle |
| 3 | FT85-113 | Ball Retainer |
| 4 | FT84-2DR | Ball |
| 5 | FT84-2E | Probe O-ring |
| 6 | FT85-9GB | Probe Assembly |
| 7 | FT85-9GBA | Handle and Probe Assembly |
| 8 | FT40-15 | Probe Washer |
| 9 | FT84-3 | Spring |
| 10 | FT86-1 | Body |
| 11 | 440-19L-60 | Safety Assembly |
| 12 | FT84-2J | Gas Shut-Off O-Ring |
| 13 | FT84-2A | Body Washer |

| | | |
|-----|----------|------------------------------------|
| 14 | FT86-20A | Pressure Line Check Valve Assembly |
| 14A | 752 | Pressure Line Check Valve |
| 14B | FT86-20 | Pressure Line Check Valve Retainer |
| 15 | 526E | Pressure Inlet Nipple |
| 16 | 874 | Hex Nut |



How Beer Flows through the Coupler

(See pictures #1 and #2 below.)

The CO₂ enters coupler through the CO₂ inlet and passes between the outside of the probe and the inside of the coupling body through the CO₂ chamber and into the keg.

The CO₂ pushes down on the beer in the keg and forces the beer up the draw tube and into the coupler probe.

The inside of the probe is bored out to just a little wider than the diameter of the check ball, from about 3/4 of an inch from the top to about and 1/8th of an inch from the bottom of the inside of the probe. The inside of the top 3/4" of the probe is bored out to about 1/2 inch.

When the beer flows through the coupler probe the check ball is pushed up against the check ball retainer in the area that has been bored out to a 1/2 inch. This allows the beer to pass by the check ball so it will not stop the flow of beer out of the keg.

When the coupler is untapped the beer pressure in the beer line pushes the check ball down against the bottom inside of the probe, shutting off the beer.

Coupler Safety

Both the Single and "T" Handle couplers include three types of one-way check valves:

1. The Thomas/CO₂ Check valve – This valve allows CO₂ flow into the coupler but prevents the beer from backing up into the gas line if gas pressure drops. This protects the gas regulators from damage. If you see beer or moisture in the CO₂ line, replace this valve.
2. The probe check ball – When the coupler is disconnected from the keg, this ball is pushed down against the inside bottom of the probe preventing the beer, from the beer line, from flowing back out through the coupler. This prevents beer spillage in keg tapping areas.
3. Keg coupler are also made with a built in pressure safety relief valve. If excessive gas pressure (usually above 40-45-lbs. +/- 5-lbs.) were applied to a keg, this valve would open to prevent damage to the keg and coupler. The valve can also be opened manually, by pulling on the safety relief valve's ring/pin. To test the safety relief valve, pull the ring a short distance out away from of the coupler and release a small amount of gas. This should be done periodically, as part of general maintenance, to test the safety relief valve.

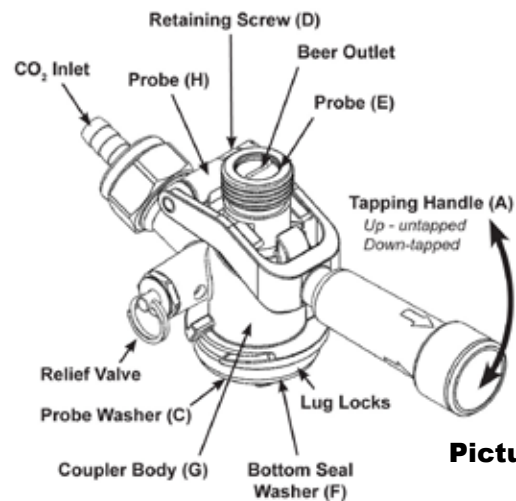

Picture 1

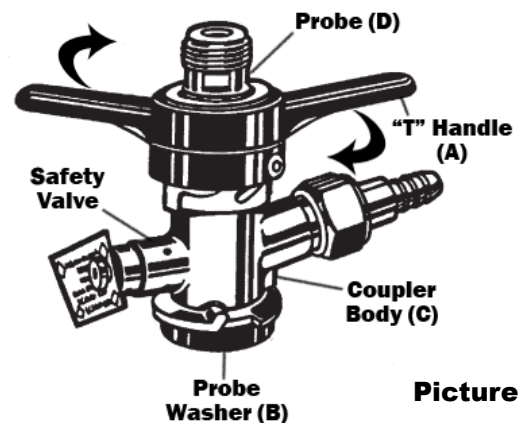

Picture 2

Coupler Maintenance

To maintain the proper functioning of the couplers, they should periodically be taken apart to inspect the probe O-rings, probe washers, bottom seal washer, Thomas/check valves, safety relief valves, check balls and ball retainers.

Additionally, the probe O-rings should be lubricated just before the coupler is reassembled to allow for ease of tapping.



Basic Coupler Troubleshooting

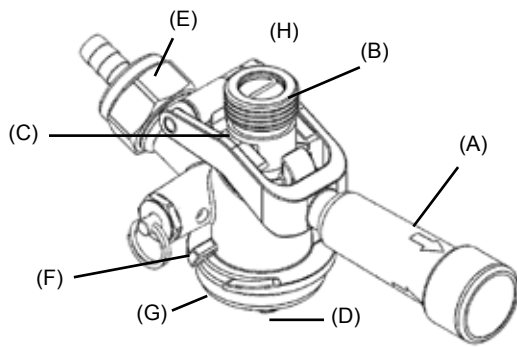

Single Handle Coupler

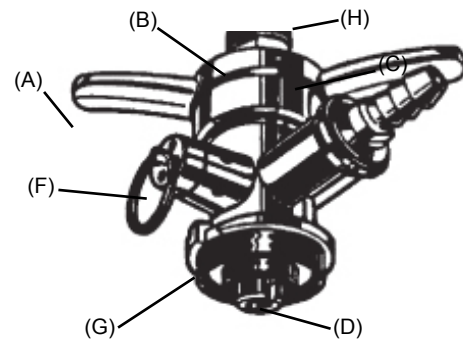

"T" Handle Coupler

| Problem | How to Detect | Possible Solutions |
|--|---|--|
| Handle (A) will not move. | Cannot tap keg | <ol style="list-style-type: none"> 1. Handle stuck. Take coupler off system, disassemble and soak in hot water. Clean, inspect parts, lube and reassemble. 2. Part may be broken, disassemble and repair. |
| Beer leaks at top of hex nut (B) | Beer is coming out | <ol style="list-style-type: none"> 1. Untap keg, remove hex nut to check that a beer line washer is in place and not cut or torn, re-attach and tighten snugly. |
| Beer leaks between top of probe and coupler body (C) | Beer is coming out | <ol style="list-style-type: none"> 1. Untap keg, remove probe and check and repair O-rings. |
| Beer leaks between the tap and the keg (D) | Beer is coming out | <ol style="list-style-type: none"> 1. Untap keg, inspect the bottom seal washer and replace if necessary. |
| CO ₂ is leaking out of CO ₂ nipple (E) | CO ₂ is coming out | <ol style="list-style-type: none"> 1. Untap keg, inspect nipple washer and replace if necessary. 2. Tighten the nipple snugly with wrench. |
| CO ₂ is leaking out of safety relief valve (F) | CO ₂ and/or beer is coming out | <ol style="list-style-type: none"> 1. Untap keg; make sure safety relief valve pin is seated properly. 2. Check CO₂ pressure to assure that it is not over 50 psi. |
| Beer going into the beer line (H) is foamy | Visually see beer bubbles as beer exits the keg | <ol style="list-style-type: none"> 1. Make sure the ideal applied gauge pressure is going to the keg. (See Systems Balancing Section for details on how to set pressure) 2. Probe washer (G) is cut, sliced or torn. Replace if necessary. |
| When faucet is pulled only moist gas comes out | No beer | <ol style="list-style-type: none"> 1. Keg is empty, tap on another keg. |
| When the faucet is pulled no beer comes out at all | No beer | <ol style="list-style-type: none"> 1. The check ball may be stuck at the bottom of the probe. Untap keg and disassemble the tap, and loosen the check ball and clean. |



Beer Line

Between coupler and faucet, beer travels through the beer line selected to fit the needs of the specific draught application.

Types of Beer/CO₂

Most forced-air draught systems use clear vinyl tubing as the beer line. While vinyl tubing is highly flexible, it is best used where lines are not secured in place and where it can easily be replaced. In later sections, we will encounter other types of tubing such as:

- Barrier and polyethylene beer line that has an exceptionally smooth inside wall that allows for a low-resistance, is easy to clean, and is the beer line used in the installation of many very long draw systems.
- Clear/colored vinyl and braided vinyl used for CO₂ gas
- Stainless steel tubing found in jockey boxes and tap towers
- Polyethylene tubing used to carry glycol coolant

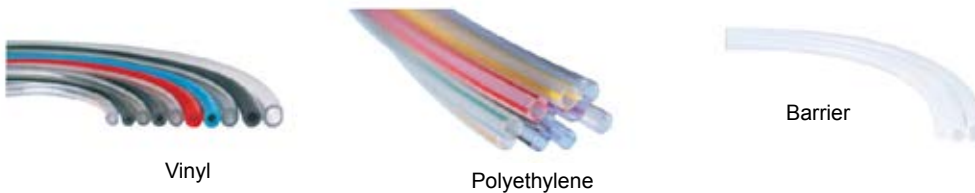

Vinyl Beer Line Sizes

Vinyl Beer Line is produced in the following sizes based on the inner diameter of the line. We will see when to use each size of vinyl line in the Systems Balancing Section later in this manual.

Chart 1

| Vinyl Beer Line | | | | |
|---------------------|---|-----------------------|-------------------|----------------------|
| Inner Diameter (ID) | Use | Single Ear Clamp Size | Double Clamp Size | Tail Piece Size (ID) |
| 3/16" ID | Beer Line | .505/.525 = 1/2" | 1/2" | 1/4" ID |
| 1/4" ID | Beer Line | .590 = 9/16" | 9/16" | 1/4" ID |
| 5/16" ID | Beer Line and CO ₂ line (Less than 50 psi) | .635 = 5/8" | 5/8" | 5/16" ID |
| 3/8" ID | Beer Line | .725/.775 = 3/4" | 3/4" | 3/8" ID |

To cut the beer line you can use the hose cutter or your crimping pliers. Use a tube gauge to determine the ID of the beer line.



Tube Cutter
Part No. 1368



One Ear Crimping Tool
Part No. 1358



Installing the Beer Line Connector

To connect the beer line to the top of the coupler, we must first put the appropriate fittings on the beer line as follows:

1. Based on the ID of the beer line (A) being used refer to Chart 1 (page 31) to select the appropriate beer clamp (B), and tail piece (D).
2. Insert the tail piece (D) through the hex nut (C), *Fig. 5.1*, and screw the hex nut (C) onto a shank (E) until it is tight. (The shank is used just for the leverage to put the beer line on the tail piece.)
3. Place the clamp (B) on the beer line (A).
4. Now dip about the last 1-in. of the end of beer line (A) in hot or boiling water, if available, to allow the beer line to soften.
5. Remove the beer line from the water and push it onto the tail piece (D), *Fig. 5.2*.
6. Use your crimping pliers (G), *Fig. 5.3*, to squeeze the clamp ear (F) together to lock the beer line onto tail piece.

This same procedure will allow you to connect the beer line to a wall bracket or a beer switch explained later in this manual.



(Fig. 5.1)



(Fig. 5.2)



(Fig. 5.3)



Connecting the Beer Line to the Coupler

Now that the beer line connector has been installed in the beer line below, it is connected to the coupler as follows (Fig 5.4):

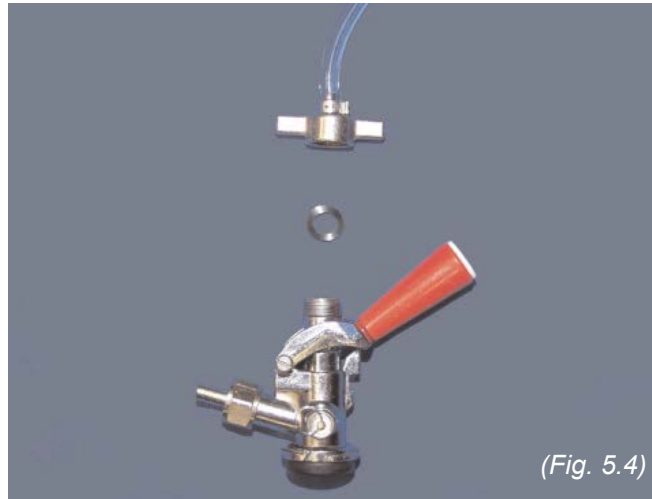

(Fig. 5.4)

To connect the beer line to the coupler insert a beer line washer into the hex nut. Now tighten the hex nut onto the coupler probe using a crescent wrench. Some couplers have probes that rotate freely in the coupler instead of being locked in place. It is the manufacturer's feeling that this will prevent kinks in the beer line. A probe wrench or Perlick Combination is used to hold the probe in place while the beer line hex nut is tightened onto the top of the coupler probe with a crescent wrench.

Connecting Two Beer Lines Together

The line being connected to the hose union is called the trunk line. The trunk line is connected to a 3/16-in. line called the restriction line, which in turn is connected to the faucet connectors.

Use the chart below to determine the size of hose union and the appropriate clamps to be used in the connection.

| ISD of the 2 Beer Lines being Connected | Hose Union Size | Hose Clamp Sizes | | | |
|---|-----------------|------------------|-------|---|----------------|
| 3/16" ID to 3/16" ID | 1/4" x 1/4" | .505/.525 | 1/2" | & | .505/.525 1/2" |
| 3/16" ID to 1/4" ID | 1/4" x 1/4" | .505/.525 | 1/2" | & | .590 9/16" |
| 3/16" ID to 5/16" ID | 1/4" x 3/8" | .505/.525 | 1/2" | & | .635 5/8" |
| 3/16" ID to 3/8" ID | 1/4" x 3/8" | .505/.525 | 1/2" | & | .725/.750 3/4" |
| 1/4" ID to 1/4" ID | 1/4" x 1/4" | .590 | 9/16" | & | .590 9/16" |
| 5/16" ID to 5/16" ID | 3/8" x 3/8" | .635 | 5/8" | & | .635 5/8" |
| 3/8" ID to 3/8" ID | 3/8" x 3/8" | .725/.750 | 3/4" | & | .725/.750 3/4" |



Faucet Standards

The majority of direct draw boxes manufactured today are equipped with refrigerated faucet standards (A) or (B). For the best dispensing results, be sure that the standard is refrigerated to the same temperature as the box. This will virtually eliminate excess foam on the first glass and will improve the ease of drawing. Either a flex hose standard (A) part (9) or a standard baffle plate (B) part (8) and properly insulated standard (A) part (17) or (B) part (7) allows for circulation of the air within the standard thus eliminating hot spots.

(A) Direct Draw Standard (with flex hose for air distribution)

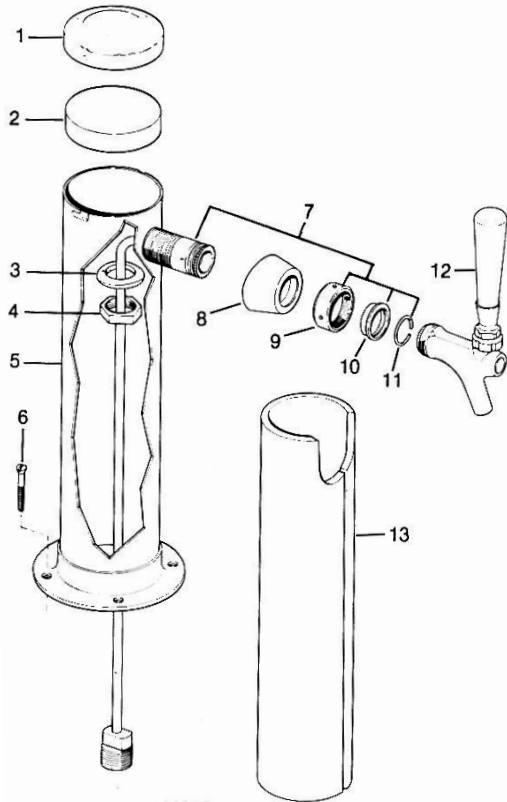

1. Top Cap
2. Rubber Insulation Disk
3. Inside Flange
4. Lock Nut
5. Tube and Flanges
6. Stainless Steel Screw
7. Shank and Tube
8. Outer Flange
9. Ferrule
10. Keeper Ring
11. Keeper Spring
12. Beer Faucet
13. Sleeve Insulation

(B) Direct Draw Standard (with baffle plate for air distribution)

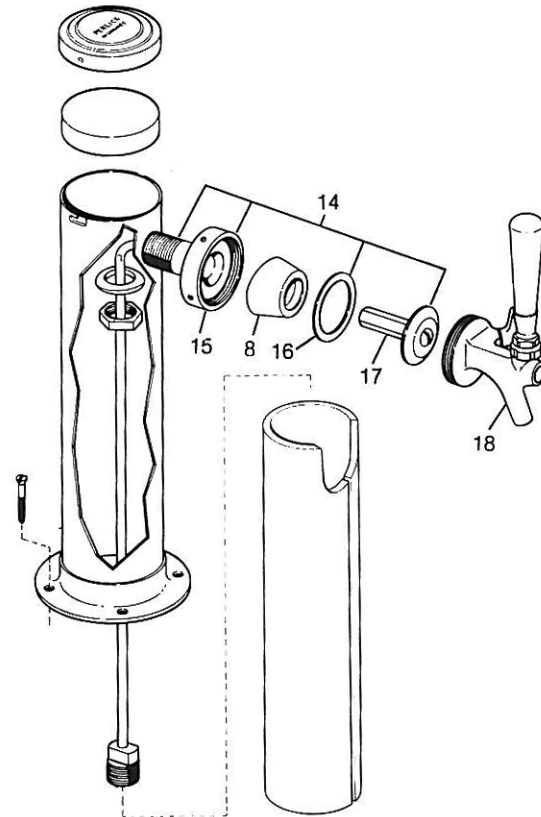

14. Tube and Shank
15. Ferrule
16. Coupling Gasket
17. Compensator – Beer
18. Beer Faucet



Connecting the Beer Line to a Faucet

The connection of the end of the 3/16-in. beer line choker to the faucet end of the system is dependent on the equipment at the faucet as follows:

Fig 5.5
Connecting Beer Line to Bent Tube Assembly



Fig 5.6
Connecting Beer Line to Straight Shank

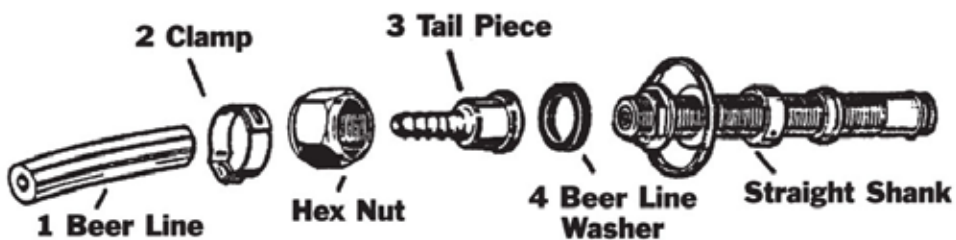

Fig 5.7
Connecting Beer Line to Tube Elbow (and Tube Shank)

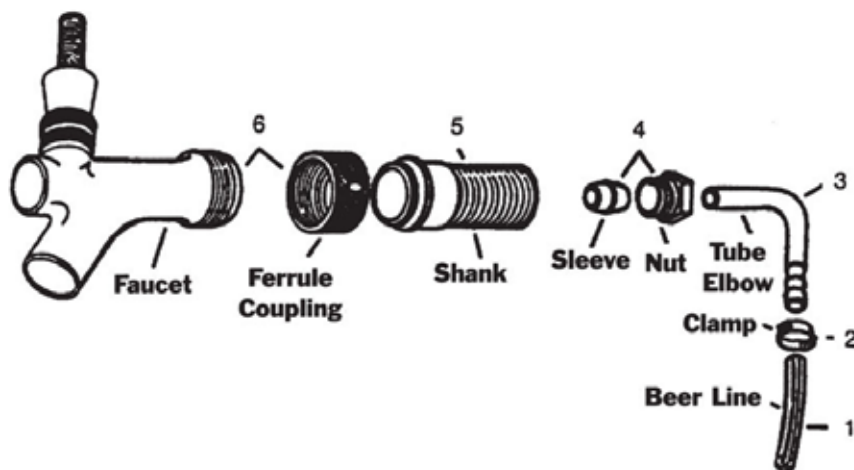
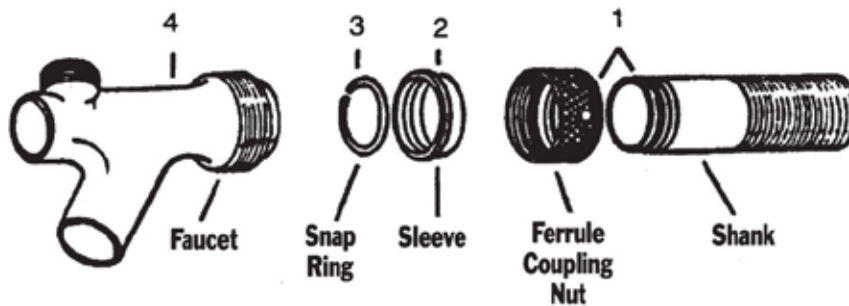

Fig 5.8
Connecting Faucet to Shank



Beer Faucets

Beer Faucet Connection

- The beer faucet is attached to the beer system by placing the threaded portion of the faucet into the coupling nut of the:
 - Beer line to bent tube assembly (**Fig. 5.5, page 33**)
 - Beer line to straight shank (**Fig. 5.6, page 33**)
 - Beer line to tube elbow (and tube shank) (**Fig 5.7, page 33**)
 - Faucet to shank (**Fig. 5.8, page 33**)

The coupling nut is then tightened snugly using a combination wrench or spanner wrench. The tip of the either wrench is inserted into one of the holes in the coupling nut and turned clockwise to tighten the faucet into the coupling nut, or counterclockwise to take the faucet out of the coupling nut.

Types of Beer Faucets

Faucets dispense beer into the beer glass. They also hold the tap marker to identify the brand of beer being dispensed. The most common faucets are generally suitable for dispensing both ales and lagers. There are two types of faucets: the vented faucet (5.9) and the ventless faucet (Fig. 5.10).

The vented faucet has two vents in the faucet which let air enter the faucet when it is closed allowing the faucet to empty into the glass instead of dripping out of the faucet.

The ventless faucet does not have the two vents that the standard faucet has. This is an advantage in that there are no vents in which yeast can build up. This prevents the opportunity of contamination of the beer from the faucet. It also eliminates the foaming problem caused when the vents do get blocked off by dried beer or yeast buildup.

Fig. 5.9 – Standard Vented Faucet

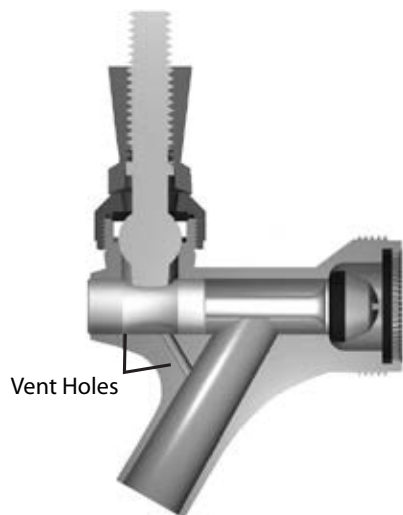
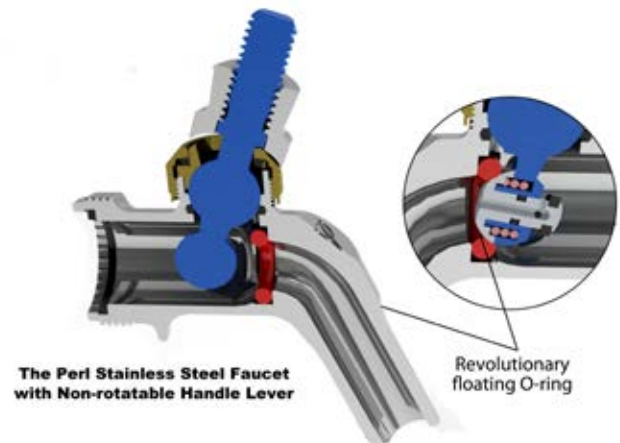

Fig. 5.10 - Ventless Faucet



Faucets

The faucet may be made out of chrome-plated brass or solid stainless steel. The stainless steel version, while more expensive to buy, is the better buy in the long run for it will outlast the chrome-plated faucet which deteriorates over time due to wear and cleaning.



Disassembly and Assembly of the Standard Beer Faucet (Fig 5.11)

To Disassemble the Faucet, follow the procedures below:

1. First remove the tap knob (8). This is done by placing a pair of pliers on the collar (7) to hold it in place while unscrewing the tap knob counterclockwise.
2. Next remove the collar (7) counterclockwise using the crescent wrench if needed.
3. Remove the compression bonnet (6) using your fingers or a pair of pliers, if needed.
4. Pull the handle lever (5) out of the faucet.
5. Now remove the bonnet washer (13) and the friction (12) from the handle lever (5).
6. Remove the shaft assembly (4) from the faucet. Inspect the seat washer (11). If it is torn, cut, pinched or twisted repair or replace it by turning the screw (3) counterclockwise.
7. Remove the coupling gasket (10) from the inside of the back of the faucet body (1) using a small bladed screw driver. (Be careful not to slice or cut this gasket or it will cause a leak between the faucet and the coupling nut.)

To Assemble the Faucet, follow the process below:

1. Place the coupling gasket (10) into the inside of the back of the faucet body (1).
2. Put the seat washer (11) back on the shaft, rounded side first. Then secure to the shaft by putting on the screw (3) and turning it clockwise.
3. Place the shaft (4) back into the faucet body in the orientation as shown in the picture. Make sure that the shaft slot (A) is lined up vertically in the faucet.
4. Place the handle lever (5) into the faucet from the top at (B). Make sure the bottom of the handle lever (5) is inserted into the shaft slot (A).
5. Next, place the friction ring (12), on the handle lever, making sure the beveled side of the friction ring is placed down so it fits nicely on the round portion of the handle lever.
6. Next place the bonnet washer (13) on the handle lever.
7. Then place the compression bonnet (6), thread on the inside pointing down, on the handle lever (5), making sure the threaded portion inside the compression bonnet goes over the bonnet washer (13) and friction ring (12). Now turn it clockwise on to the top of the faucet until it is finger tight.
8. Screw the collar (7) onto the handle lever (5) clockwise until it touches the bonnet washer (6). Then unscrew it back one-half turn.
9. Finally, screw your tap knob (8) clockwise back onto the handle lever until it touches the collar. If the tap knob is not lined up properly (logo facing the consumer) then unscrew it just enough to line it up properly. Hold the tap knob in place and using a pair pliers, screw the collar counterclockwise back up to the tap knob until it is very tight.

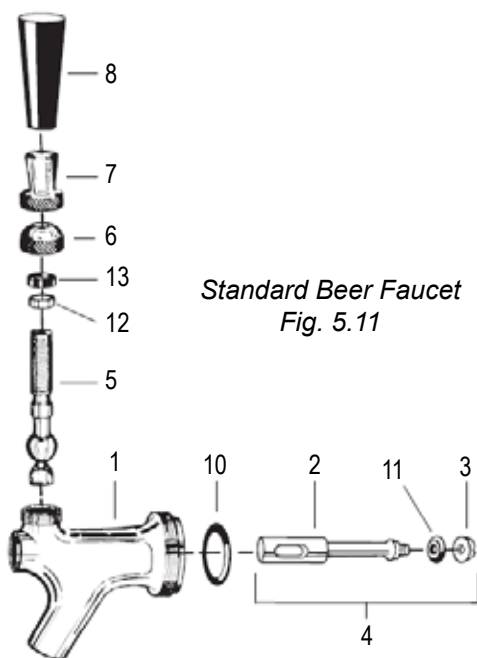

| Item | Part Number | Description |
|------|-----------------------------------|--------------------------|
| 1 | 308-1X* | Faucet Body |
| 2 | 408-2A | Shaft |
| 3 | 308-10N | Screw |
| 4 | 43473-26* | Shaft Assembly |
| 5a | 408-27 | Handle Lever (brass) |
| 5b | 410-27 | Handle Lever (stainless) |
| 6 | 408-15* 408-15PB* 408-15TF* | Compression Bonnet |
| 7 | 408-16 * 408-16TF | Collar |
| 8 | 308-38 | Knob |
| 9 | 408-25* | Handle Assembly |
| 10 | 308-3-2P | Coupling Gasket |
| 11 | 307-3-2P | Seat Washer |
| 12 | 308-55 | Friction Ring |
| 13 | 307-8-2P | Bonnet Washer |

*Add PB for polished brass or TF for tarnish-free brass



Ventless Faucet (Fig 5.12)

Disassembly and Assembly of the Ventless Beer Faucet

To Disassemble the Ventless Faucet, do the following:

1. First remove the tap knob (9). This is done by placing a pair of pliers on the handle jacket (8) to hold it in place while unscrewing the tap knob counterclockwise.
2. Next remove the handle jacket (8) counterclockwise using the pliers if needed.
3. Remove the compression bonnet (7) using your fingers or a pair of pliers, if needed.
4. Now remove the O-ring (2a).
5. Pull the lever handle assembly (5/6) out of the faucet and remove the second O-ring (2b).
6. Now remove the bearing cup (6a) from the handle lever (5a).
7. Lastly, remove the O-ring seat (3) and the coupling gasket (4).

To Assemble the Ventless Faucet, follow the process below:

1. First insert the O-ring Seat (3) and the coupling gasket (4) into place in the back of the faucet (1).
2. Place the bearing cup (6A) back onto the handle lever (5A).
3. Put one of the "O" rings (2b) on the bottom of the handle lever assembly (5/6) and insert assembly back into the top of the faucet body (1).
4. Now drop the second O-ring (2a) down on the handle lever (5/6) and into place.
5. Then place the compression bonnet (7), thread on the inside pointing down on the handle lever (5/6), making sure that the threaded portion inside the bonnet goes over the "O" ring (2a). Now turn it clockwise onto the faucet body until it is finger tight.
6. Screw the handle jacket (8) onto the handle lever (5/6) clockwise until it touches the compression bonnet. Then unscrew it back one half turn.
7. Finally, screw your tap knob (9) clockwise back onto the handle lever (5/6) until it touches the handle jacket (8). If the tap knob is not lined up properly (logo facing the consumer) then unscrew it just enough to line it up properly. Hold the tap knob in place and using a pair of pliers, screw the handle jacket (8) counterclockwise back up to the tap knob until it is very tight.

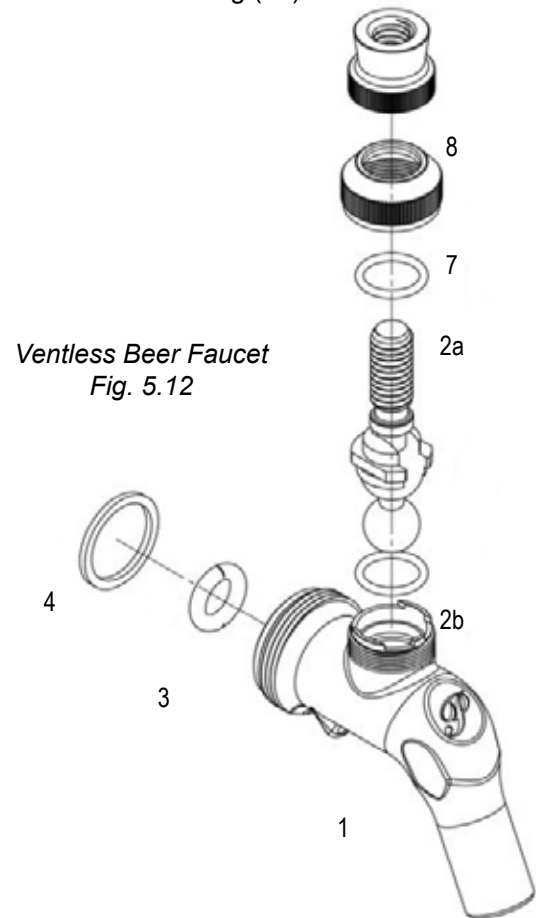

| Item | Part Number | Description |
|------|----------------------|-----------------------|
| 1 | | Faucet Body |
| 2 | 425-8 | O-ring |
| 3 | 43838 | O-ring Seat |
| 4 | 308-3-2P | Coupling Gasket |
| 5 | 68157-1 | Handle Lever |
| 5A | 67030 | Handle Lever Assembly |
| 6 | 67382-1 | Bearing Cup |
| 6A | 67382-1 | Bearing Cup |
| 7 | 43835-2 43835-2TF | Compression Bonnet |
| 8 | 408A-16 408A-16TF | Handle Jacket |



Basic Faucet Troubleshooting – Standard and Ventless Faucets

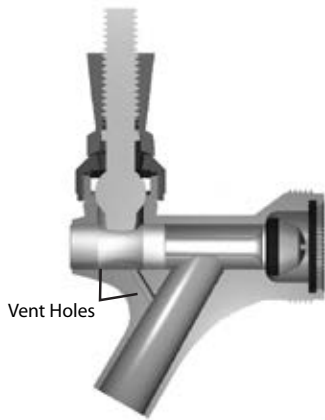

Standard Faucet

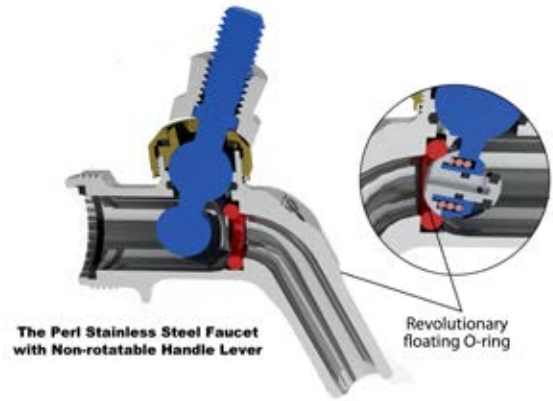

Ventless Faucet

| Problem | How to Detect | Possible Solutions |
|--|--|--|
| Handle Lever (A) will not move | <i>Cannot open faucet</i> | <ol style="list-style-type: none"> Untap keg, remove faucet from coupling nut (D) and remove compression bonnet (B). Disassemble and soak faucet in hot water. Reassemble to see if it works. Inspect parts, to see if broken, repair and replace. Handle lever (A) may have been inserted into shaft (C) or top of faucet incorrectly. |
| Beer leaks at top between compression bonnet (B) and top of faucet (E) | <i>Beer is leaking out</i> | <ol style="list-style-type: none"> Untap keg, remove faucet then remove compression bonnet (B). Inspect bonnet washer (F) or O-ring (F) to check it is not cut or torn. Replace if necessary and reattach bonnet coupling to faucet and reinstall faucet. |
| Beer leaks between coupling nut and faucet at (G) | <i>Beer is leaking out</i> | <ol style="list-style-type: none"> Untap keg, remove faucet, and then remove coupling gasket (H) and/or O-ring seat (F), inspect and replace if needed |
| Beer leaks out of front of faucet at (J) | <i>Beer is leaking out</i> | <ol style="list-style-type: none"> Untap keg, remove standard faucet and then inspect shaft (C): it may be worn. Replace if needed. Untap keg, remove ventless faucet and inspect the O-ring seat (F) and/or bottom of handle lever (A) for damage. Replace as needed. |
| Faucet drips at mouth (L) | <i>Beer is leaking out</i> | <ol style="list-style-type: none"> Vent holes on standard faucet may be clogged. Untap keg, remove faucet and run a pipe cleaner up and down both vent holes. On standard faucet the screw (M) and seat washer (N) on the shaft may be loose; tighten screw. On standard faucet the seat washer (N) may be worn, cut, nicked or sliced. Inspect and replace if necessary. |
| Beer swirls when it comes out of the faucet | <i>Beer flow is cupped or swirls when it pours</i> | <ol style="list-style-type: none"> On standard faucet the vent holes may be plugged. Untap keg, remove faucet and run a pipe cleaner up and down both vent holes. |

Imported Beer Faucets:

Many imported stout and ale beers in kegs use special faucets that are used in conjunction with nitrogen gas to give them a special pour. Contact the importer for more information on these faucets.



Completing the Beer System

We have discussed the basics of the building of a beer system above. There are a few more basic components needed to complete the system as discussed below:

Faucet Standards and Towers:

There are a number of faucet standards and towers to which the beer line is attached. Here are a few of the multitude of varieties:

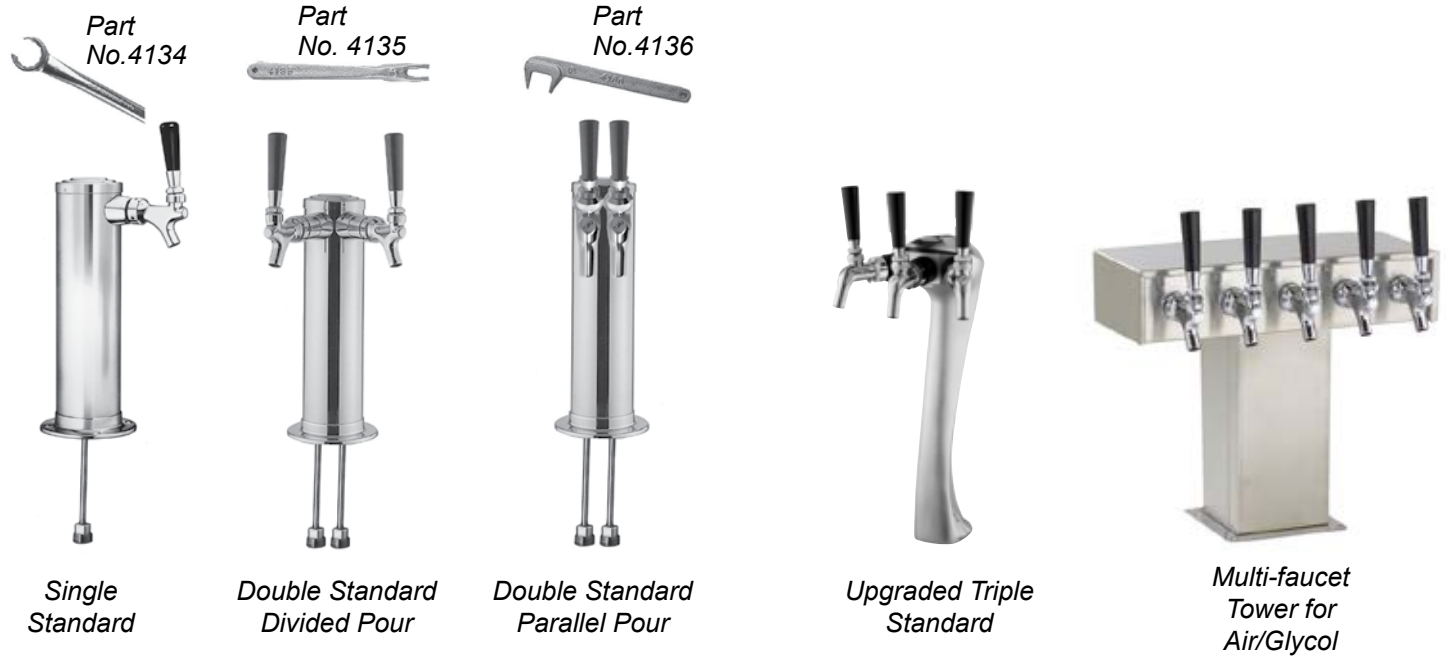

Beer Standard Wrenches

To install or remove the shank and bent tube assemblies (S&BTA) in the single and double standards above, special tools have been created to assist in this process as pictured above.

- Single S&BTA Wench (*Part No. 4134*)
- Divided Double Standard S&BTA Wench (*Part No. 4135*)
- Divided Double Standard S&BTA Wench (*Part No. 4136*)

Drip Tray

Located directly under the faucet(s) is a drip tray. This tray is mounted on the counter and is connected to a drain that runs directly into the account's plumbing. The drain captures beer overflow from the glass. Drip trays come in all sizes and shapes to meet the demands of the account.

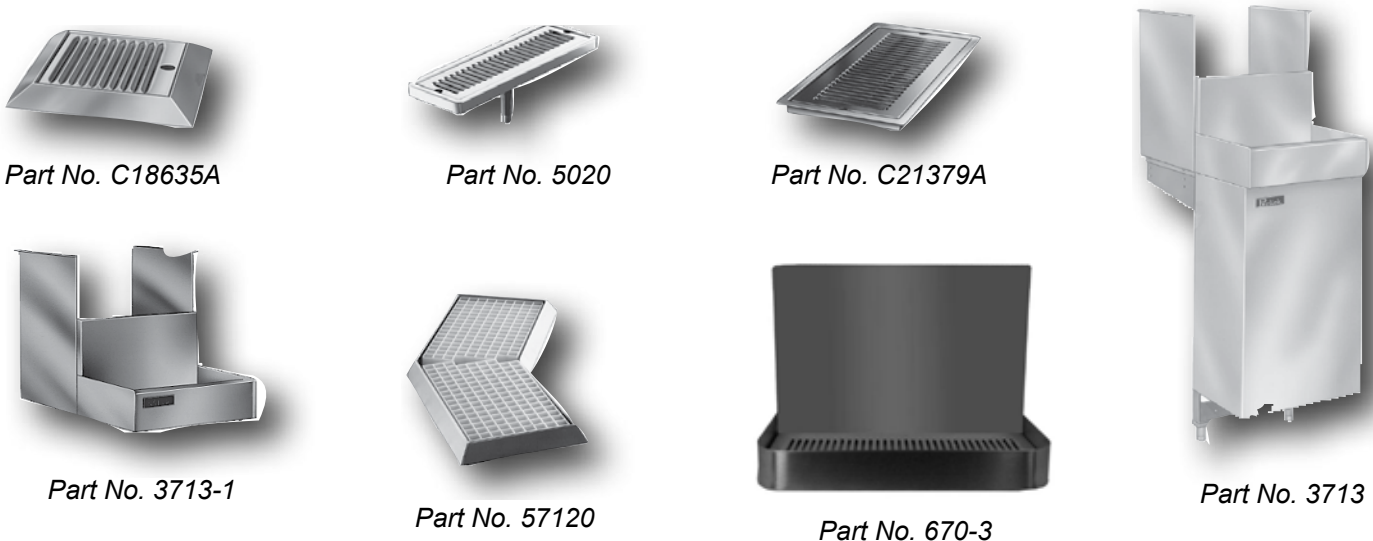



Section 6

Carbon Dioxide/Nitrogen



6



Carbon Dioxide and Nitrogen

Why Carbon Dioxide (CO₂)?

Carbon dioxide is the gas that is produced during the making of the beer. It gives the beer its effervescent taste and bubbly head. Thus, it is important to use CO₂ when dispensing draught beer products.

Use of CO₂ in a Draught Beer System

Because CO₂ is the primary gas in the beer, we use CO₂ to push the beer out of the keg, through the beer lines and out through the faucet. This assures that we maintain the proper amount of CO₂ in the beer and maintain its brewery fresh flavor when served to the consumer.

Characteristics of CO₂ in a CO₂ Tank

The CO₂ used to push draught beer through a draught beer system is usually supplied from a CO₂ tank.



(Fig. 6.1)

When the tank is filled, it is about ½ full of liquid CO₂ with the upper ½ of the tank filled being CO₂ gas (See Fig. 6.1).

The tank pressure is dependent on the ambient temperature regardless of tank fill level and will vary from 600 to 1,200 psi until empty. (See Appendix F)

The CO₂ gas in the tank pushes the beer through the system. As the gas is being used the liquid CO₂ is continuously converting to a gas. Once the liquid gas is used up the pressure in the tank will slowly drop as the remaining CO₂ gas is used.

Gas Source

Gas selection and purity affect the freshness and quality of the beer served through the draught system.

Remember: The gas you use fills the keg as the beer drains. Thus, off-flavors or impurities in the gas quickly migrate to the beer to spoil its freshness and flavor.

Never Use Air to Pressurize a Keg

Systems that use compressed air as a dispense gas expose beer to oxygen, which produces stale paper- or cardboard-like aromas and flavors in the beer.

Brewers go to great lengths to keep oxygen out of beer to avoid these undesirable stale characteristics.

Air compressors also push contaminants from the out-

side atmosphere into the keg, increasing the chance of beer-spoiling bacteria and off-flavors. For these reasons, compressed air should never be used in direct contact with beer.

CO₂ Quality

All gas used for beer dispensing should meet the specifications of the International Society of Beverage Technologists or the Compressed Gas Association (see Appendix A).

Gas used for draught dispense should be “beverage grade.” Retailers may purchase this gas in cylinders that will be delivered by the gas vendor and swapped out when empty. Such cylinders are filled, maintained and inspected by the vendor.

High-volume users may purchase a bulk CO₂ gas vessel, known as a Dewar, which will be filled on location from a bulk gas truck. Bulk tanks can provide CO₂ for both soda and beer.

Which Gases to Use in a Draught Beer System

Short draught beer systems usually use pure CO₂ or straight nitrogen if it is a “nitro” beer to push the beer through the system.

As we will see later many accounts with long draws will need to use a blend of CO₂ and nitrogen, or straight nitrogen, if it is a “nitro” beer, to provide enough pressure to push the beer through the lines without over carbonating the beer.

Measurement of CO₂

CO₂ is measured by the number of pounds of liquid CO₂ put in the tank. The most common sized tanks are 5-lb., 10-lb., 20-lb. and 100-lb. tanks.

Each pound of CO₂ will push 1 to 1½ half barrels of beer through a draught system.

Example: 20 lbs. tank pushes approximately 20 to 30 half barrel kegs.

CO₂ and Nitrogen Tank Safety Relief Valve

CO₂ and Nitrogen tanks both are equipped with safety relief valves that will open and vent the tanks contents if;

The tank is overfilled or

Stored at an extremely hot temperature.

The tank safety relief valve is located on the tank neck just below the shut-off valve. The safety relief valve is designed to release the pressure of the tank instead of bursting the tank.



Nitrogen

At room temperature the nitrogen in a nitrogen tank (Fig. 6.2) is a gas unlike CO₂. Nitrogen is an inert gas so it does not penetrate, and thus, does not over carbonate the beer.

“On-site” Nitrogen Producing Systems

For the high-volume users of nitrogen, “on-site” nitrogen producing/generating system and storage systems are available for installation and can offer convenience and cost savings vs. the use of nitrogen cylinders. These systems separate/strip the nitrogen from the air, filter it, store it and blend it with the CO₂ source in the account.

Although “up front” costs may seem high, the system can pay for itself over three to five years by totally replacing nitrogen cylinders, lowering cost of nitrogen and reducing the labor costs incurred in handling nitrogen cylinders.



(Fig. 6.2)

What is the Proper CO₂ Pressure for Each Brand of Draught Beer?

It is very important to tap all draught beer products using its required pressure settings, which:

- Maintains the natural carbonation in the beer,
- Makes sure that the retailer can pour the proper head on each beer and
- Assures that the draught beer tastes like the brew master intended them to taste.

The proper CO₂ pressure setting for each brand of beer is dependent upon the:

- The pressure at which the beer was packaged
- The altitude of the retail account in which the beer is being served and
- The temperature of the beer.

Go to the Systems Balancing section of this manual to see specifically how you determine the appropriate applied gauge pressure for any system you are installing. You may also go to Appendix E to learn about the absolute pressure at which the beer is packaged.



Under and Over Carbonated Beer

As noted on previous page, it is important to maintain the proper pressure on the keg of draught beer. This allows the natural carbonation in the beer to stay in balance and allow the beer to pour *trouble free*

The following illustrations depict what will be the effect of pushing draught beer with:

1) The correct CO₂ pressure, (Fig. 6.3):

Applying the correct pressure from the CO₂ supply allows the beer to maintain its natural carbonation level. The pressure from the CO₂ pushing on the beer equals the pressure in the beer thus the natural CO₂ remains in the beer and maintains the quality of the beer.



(Fig. 6.3)
Correct pressure

2) Under carbonation, (Fig. 6.4):

Too little CO₂ pressure will cause the natural carbonation to break out of the beer in the keg and the beer line. This causes the beer to become flat, have an unacceptable taste and large CO₂ bubbles in the head. It also creates drawing problems as the CO₂ that breaks out of the beer in the beer line floats to the high spots in the system. This creates pockets of foam:

- Right above the coupler - Right behind the faucet
and
At any other high spot in the system.

When the beer is drawn into the glass these pockets of foam flow into the glass causing excess foaming. The longer the system sits between draws the larger the foam pockets and the worse the pouring problem.

(Fig. 6.4)
Under carbonation



3) Over carbonation, (Fig. 6.5):

When too much CO₂ pressure is applied, the CO₂ begins to penetrate into the beer in the top of the keg. The excess CO₂ builds up in the beer and causes over carbonation. This extra carbonation is unnatural to the product and alters the taste of the beer. Over carbonation also causes drawing problems. The higher the pressure, the longer the keg is on tap, and/or the colder the temperature the faster it will over-carbonate.

(Fig. 6.5)
Over carbonation



Care and Handling of CO₂

Because a full tank of CO₂ is under such high pressure, it must be handled with extreme care.

- 1) Always connect the CO₂ cylinder to a regulator, otherwise you'll be releasing 600+ lbs. directly to the keg.
- 2) Always check the latest test date stamped on the cylinder neck before installation. If it is over 5 years old, do not use the tank and return it to the supplier for credit and inspection.
- 3) Always secure the CO₂ tank in a vertical position with a safety chain or CO₂ tank holster. This will prevent the tank from falling over and allowing the liquid CO₂ to seep into the regulator and gauges, thus causing damage.
- 4) Breathing high concentrations of CO₂ can be deadly!
 - a) Take care to prevent CO₂ buildup in enclosed spaces such as cold boxes/walk-in coolers.
 - b) System leaks or beer pumps using CO₂ can cause this gas to accumulate in the cooler. To prevent this, beer pumps driven by CO₂ must be vented to the atmosphere.
 - c) CO₂ warning alarms are available and are recommended for installations in enclosed areas such as cold boxes/walk-in coolers containing CO₂ fittings and gas lines.



- 5) Always ventilate and leave the area if CO₂ leakage has occurred. If safely possible turn off the CO₂.
- 6) Only use tanks and regulators that are equipped with a safety release valve.
- 7) Always keep a CO₂ tank away from excessive heat. If the temperature in the tank rises the pressure may rise to dangerous levels. (See Appendix F – CO₂ Tank Pressure.
- 8) Keep the CO₂ tank out of the cooler. If the tank is stored in the cooler, the CO₂ gas may liquefy which will reduce the usable pressure. Keep tank at room temperature for maximum efficiency and safety.
- 9) If the retailer turns the CO₂ off when closed, untap the kegs to seal them and keep the beer from going flat.

CARBON DIOXIDE

Primary CO₂ Pressure Regulator

The pressure regulator reduces the pressure and flow rate of the CO₂ from the tank to the desired level in the keg.

Regulator

A regulator adjusts and controls the flow of gas from any source.

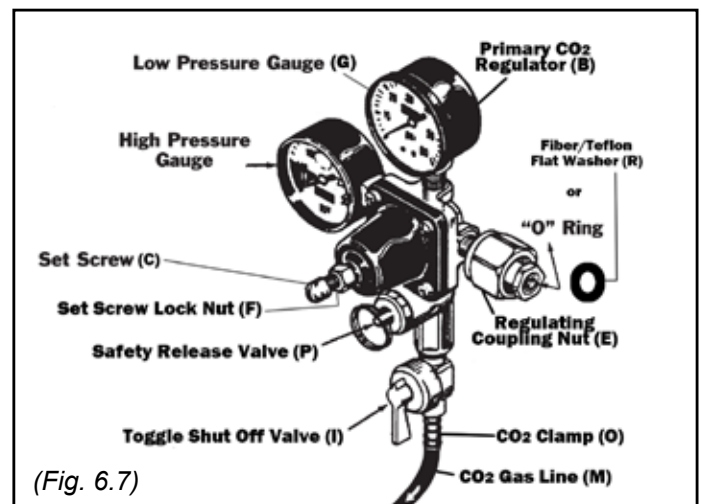
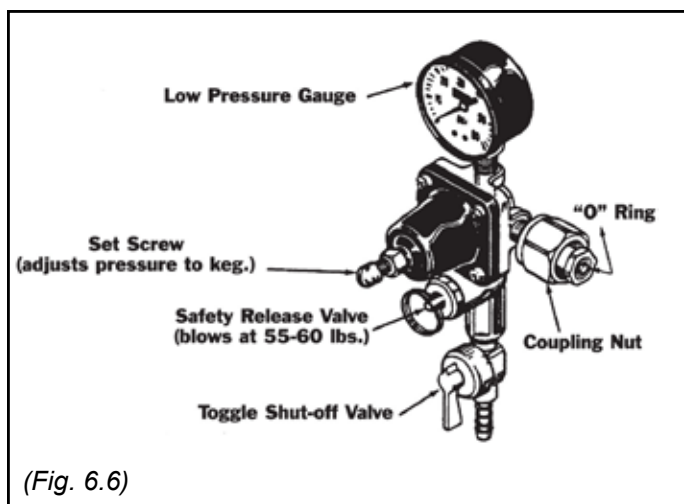

See page 44 for larger views of regulators

Each regulator typically has at least one (Fig. 6.6) and often two pressure gauges (Fig. 6.7) that helps in setting pressures and monitoring gas levels.

Internal valves and the adjustment set screw "C" control the actual flow of gas from source to the destination.

Primary Regulators

All gas systems employ a primary regulator attached to the gas source, namely a portable bottle or bulk tank.

This regulator typically contains two gauges: one high-pressure gauge, Picture 2 part "H", showing the tank or supply pressure, and a secondary low-, or regulated low-pressure gauge, Picture 2 part "G", showing the pressure being delivered from the regulator.

Some simpler regulators may only contain one gauge, Picture 1, displaying the delivered low pressure, Picture 1 "G". Single gauge Primary CO₂ regulators make it more difficult to predict when the bottle is getting low on CO₂.



(Fig. 6.6) - 1-Gauge Regulator (from page 43)

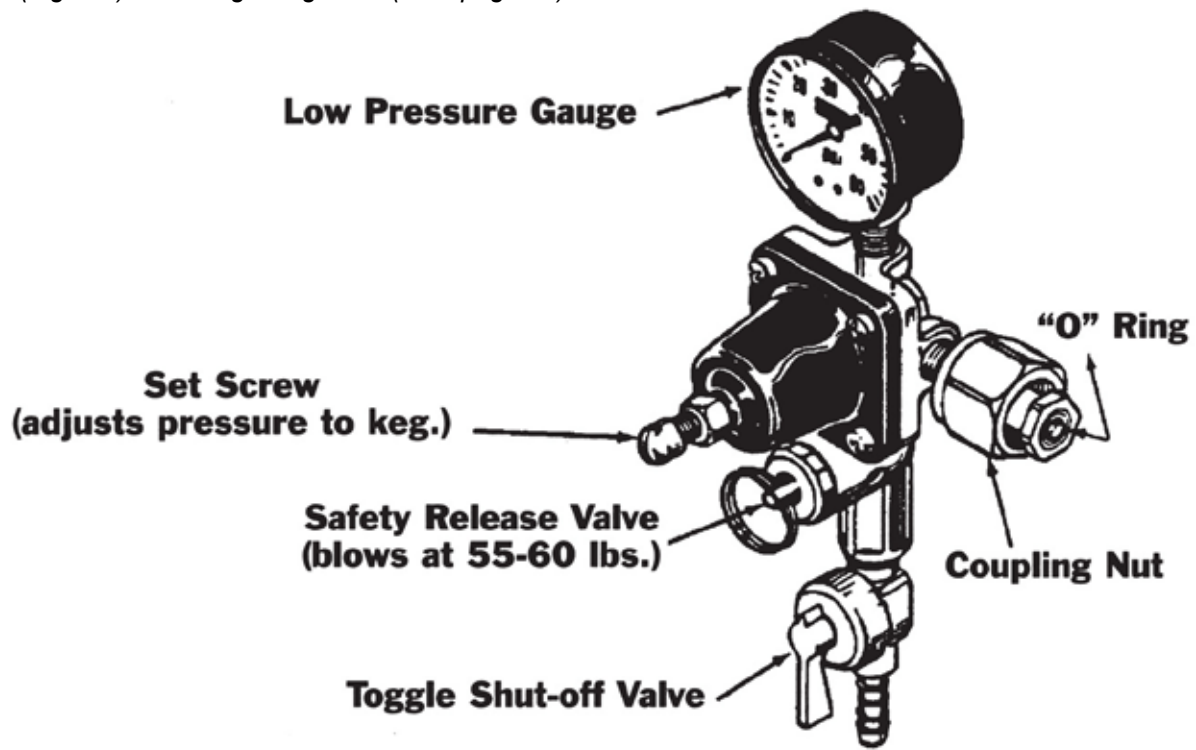

(Fig. 6.7) - 2-Gauge Regulator (from page 43)

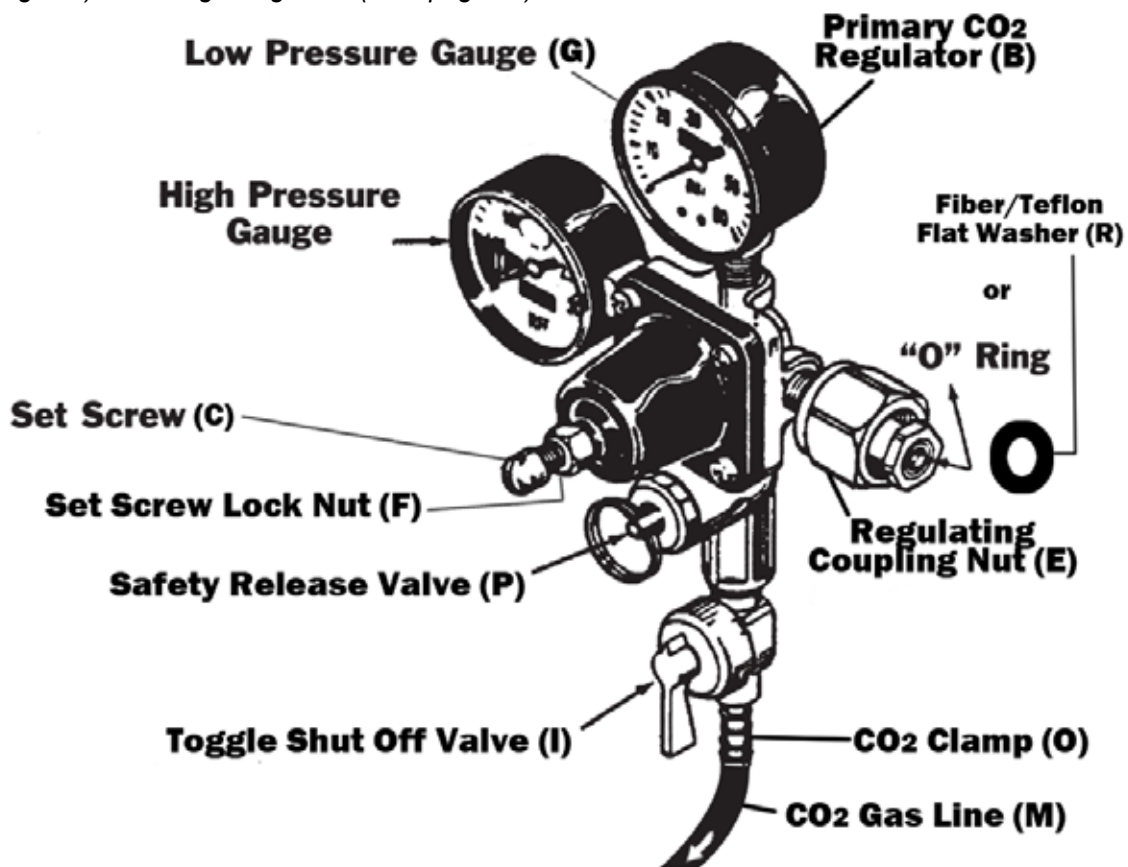

Some suppliers provide jockey box (party equipment) regulators preset with no gauges as the gauges on party equipment are easily tampered with by the user or damaged in transit.

Regulators are attached to the gas bottle with either an integrated O-ring seal or a fiber or Teflon flat washer.

Primary Regulators Maintenance

The O-ring needs to be replaced occasionally to prevent leaks and should be inspected every time the bottle is changed. The fiber washer and Teflon washers (R) should be replaced each time a CO₂ tank is changed.

Primary Regulators Safety Valves

Many regulators are equipped with one or more shut-off valves located on the low-pressure outlet. This allows the down line CO₂ to be shut off without changing the primary CO₂ regulator set screw "E" or shutting off the main tank drum valve.

A primary regulator must also contain a safety relief valve to prevent dangerous system pressures in case of a malfunction or frozen regulator. Bottled CO₂ pressure can exceed 1,000 psi, creating an extreme hazard if not handled properly.

Nitrogen Regulators

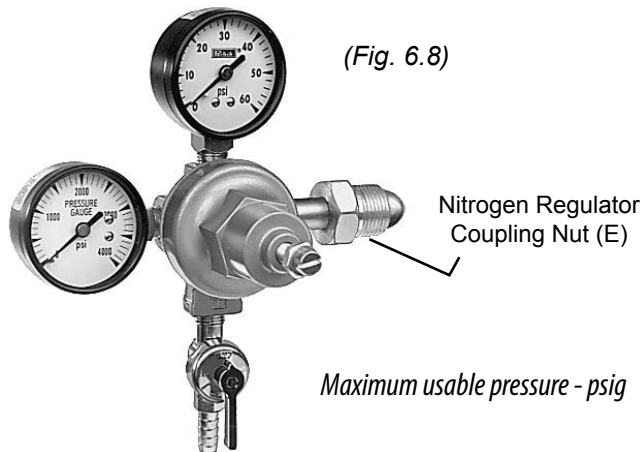

Nitrogen regulators (Fig. 6.8) are designed for higher pressures and have a male thread with a conical coupling fitting (E), Picture 4, that (depending on the design) seats with or without an O-ring.

Adjusting the Pressure Gauge

- 1) The pressure on the low-pressure gauge (G) can be changed by adjusting the Set Screw (C) on the face of the regulator as follows:
 - a) Make sure that the CO₂ tank is on and has gas.
 - b) Insert and hold a bladed screwdriver in the set screw (C).
 - c) Then using a crescent wrench turn the set screw lock nut (F) counterclockwise two turns to unlock the set screw (C).
 - d) Now turn the screwdriver clockwise to increase the pressure and counterclockwise to decrease the pressure.
 - e) To turn the regulator off, continue to turn the set screw (C) counterclockwise until the low-pressure gauge (G) reads 0 psig.
 - f) Once you select your final pressure, hold the screw-driver in place while you use the crescent wrench to tighten the set screw lock nut (F).



Secondary Regulators

To make sure that each brand of draught beer on a draught beer system receives the correct amount of pressure to maintain its brewery specifications, it may be necessary to have a secondary regulator for each brand of beer on tap.

Different brands of draught beer have different levels of CO₂ in the beer and thus will need to have a different applied pressure to make sure that the beer does not over or under carbonate.

Secondary regulators are usually located inside the walk-in cooler or keg box where each secondary regulator is set with the required pressure for the beer on tap (Fig. 6.9).

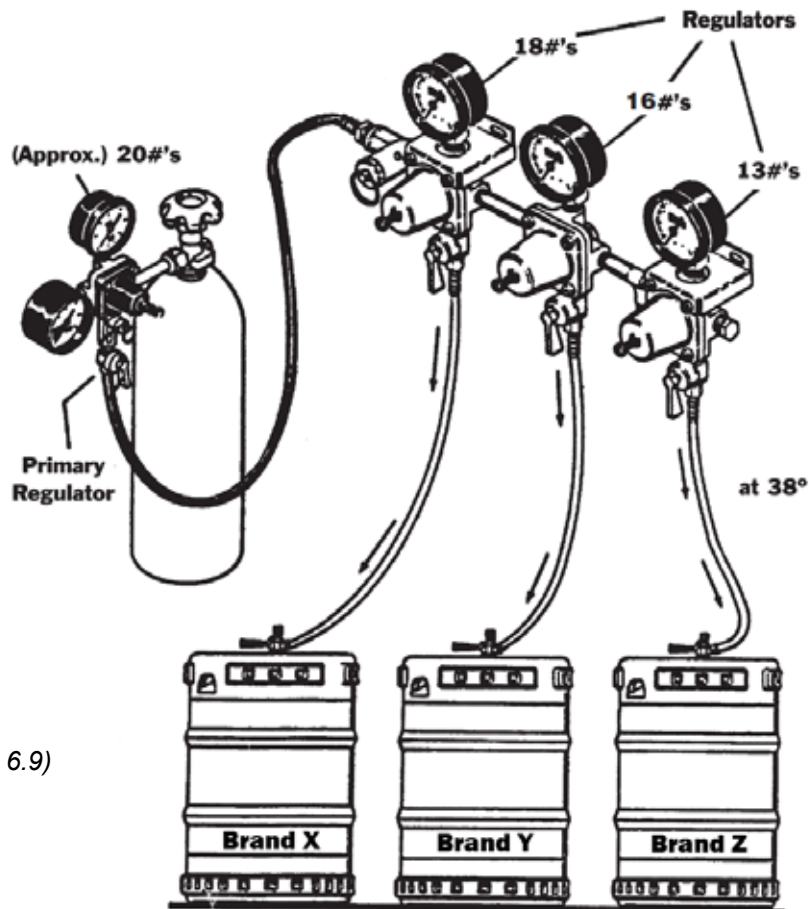

(Fig. 6.9)

CO₂ System Safety Relief Valves

Note: It is recommended that all draught beer CO₂ systems have at least four safety relief valves in the system. Typically there is a safety relief valve:

1. On the low pressure side to the primary regulator
2. On the low pressure side of the secondary regulator
3. On the air distributor
4. On the CO₂ inlet of the coupler

If there are not at least four safety relief valves in the CO₂ system, discuss with the retailer to have the additional relief valves installed.



Safety Relief Valve
5/16" hose tail piece inlet
and outlet

Part No. 32644-60



Air Distributor with shut-off
and 53-lb. Safety Relief
Valve

Part No. 20852-3



Part No. 20852-2



Method of Testing the Accuracy of the Low Pressure Side of the Primary or Secondary Regulator:

Perlick Pressure Tester (Fig. 6.10):

- 1) Turn off the pressure source.
- 2) Remove existing tap coupler (A) from the keg and, insert it into one end of double flusher (B).
- 3) Assure that the screw thread cap and washer (C) are secured to top of the Perlick tester (D). Insert the bottom of the tester (D) into the other end of the double flusher (B)
- 4) Turn on both the tester and coupler by turning on the coupling handle (F) and the tester handle (G).
- 5) Read tester regulator gauge (E). Reading on the tester (D) and on the CO₂ low-pressure gauge should be the same. If the regulator gauge is more than 2 lbs. higher or lower, it may need to be recalibrated or it may be a faulty regulator and should be repaired or replaced.
- 6) This tester can also be:
 - a) Attached directly to the keg to take its temperature and pressure or
 - b) Directly into a CO₂ line to determine the pressure in the line.

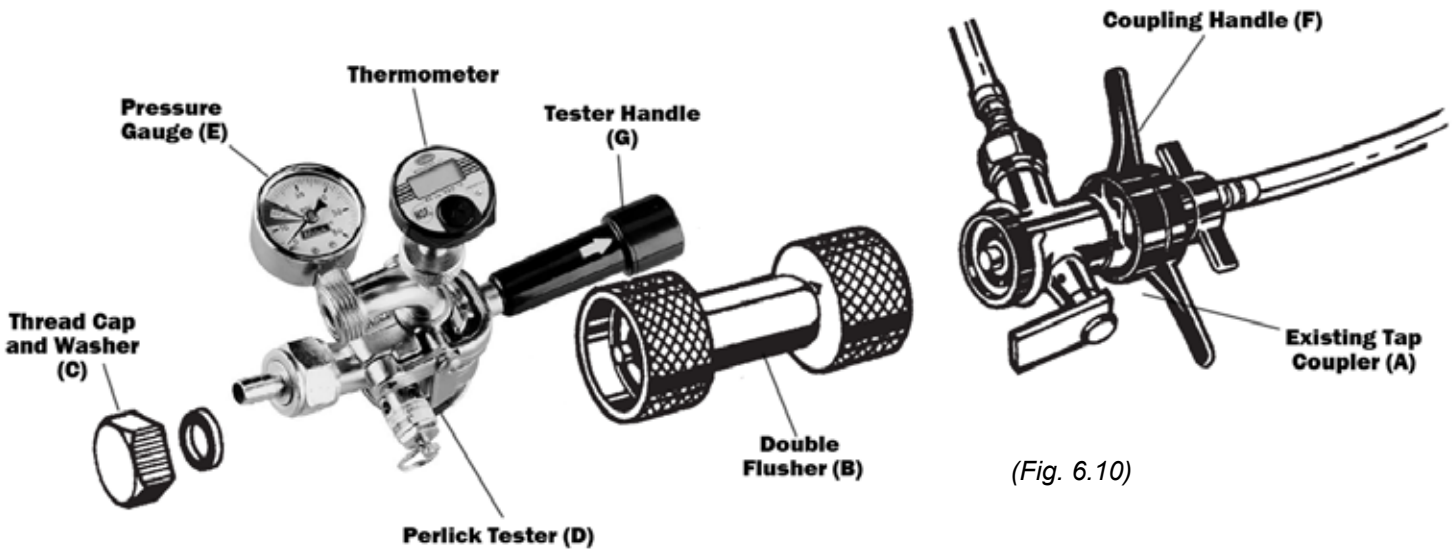

Cleaning Cup Tester (Fig. 6.11):

- 1) Untap and remove the tap coupler from keg.
- 2) Turn shut-off valve "B" to "off" position, perpendicular to CO₂ line.
- 3) Turn shut-off valve "D" to "on" position, parallel to the CO₂ line.
- 4) Insert cleaning cup tester fitting "E" onto coupler.
- 5) Read CO₂ pressure on gauge "C". Reading should coincide with reading on low-pressure gauge of the regulator. If it doesn't, it may need to be recalibrated (see next page) or it may be a faulty regulator and should be repaired or replaced.
- 6) This tester can also be:
 - c) Attached directly to the keg to take its temperature and pressure or
 - d) Directly into a CO₂ line to determine the pressure in the line.

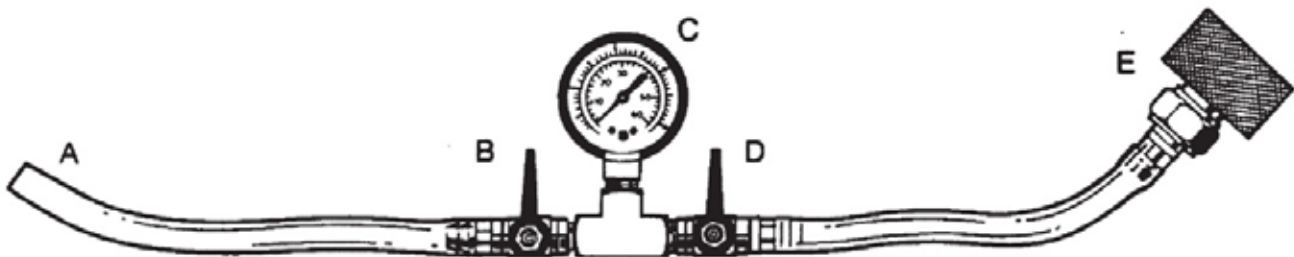

(Fig. 6.11)



Troubleshooting Primary and Secondary Regulators

CO₂ regulators may malfunction due to one or more of the following causes:

Creeping regulator

Problem: Regulator allows pressure to increase during idle periods. The low-pressure gauge will show a slow “creeping up” from the original set pressure, creating either wild or over-carbonated beer.

How do you detect this problem?

Write down the applied pressure setting at the end of the evening and then check the setting in the morning. If the pressure has risen, you have a creeping regulator.

Solution: Have regulator repaired or replaced.

Sluggish regulator

Problem: Regulator allows pressure to drop off as beer is being drawn resulting in possible flat beer.

How do you detect this problem?

Observe the low-pressure gauge as beer is being drawn. If the pressure drops and doesn't bounce back, you have a sluggish regulator.

Solution: Have regulator repaired or replaced.

Leaks

Problem: After properly installing the regulator and setting the proper pressure, the CO₂ tank becomes empty in a short period of time.

How do you detect this problem?

Turn off the CO₂ source and observe the high-pressure gauge on the primary CO₂ tank regulator. If the needle drops, you have a leak.

Solution: To isolate the source of the leak, first close the primary CO₂ regulator's toggle shut-off valve and install a new CO₂ tank, if the other is empty. Now turn the CO₂ tank on and then off to fill the regulator. Let the regulator stand idle for approximately 30 minutes. Observe at the high-pressure gauge, if it has one; if not look at the low pressure gauge. If the pressure has fallen, the leak is located in or around the regulator.

To find the exact location of a leak in the regulator use a solution of soapy water to pinpoint the leak.

If the pressure has not fallen, open the toggle shut-off valve and watch the low-pressure gauge. The gauge's needle might drop and then rise. Should this happen the leak is located in the line or coupler. Untap the couple from the keg. Turn the CO₂ tank back on and off. If the gauges go down, the leak is more than likely in the CO₂ line to the coupler.

If not the leak is most likely in the tap coupler. You should take this opportunity to check your coupler CO₂ connections with the soapy liquid to test for the leaks, and repair or replace defective parts.

Regulator freezes

Problem: The regulator freezes.

This usually occurs when:

- A) A large amount of beer is being dispensed over a relatively short period of time or
- B) There is a huge CO₂ leak in the system.

Solution:

- A. Change regulator to a larger size or split the number of faucets the regulator must handle. Regulators are designed to handle three faucets. If more faucets need CO₂, get more CO₂ tanks.
- B. Use process above under leaks to isolate, detect and fix the source of the leak.

Beer in Regulator

Problem: Beer has backed up into the regulator.

Solution: Check the CO₂ check/Thomas valve in the tap coupler and repair or replace. Put on another working regulator and clean and/or replace old regulator.

Tank is on, but regulator shows no reading.

Problem: Tank is empty.

Solution: Replace tank .

Problem: Tank is full.

Solution: Regulator is malfunctioning. Have it repaired or replaced.

High-pressure gauge is in RED

Solution: This means that the tank is almost empty.

No adjustment is needed. Simply replace CO₂ tank.

Gauge has been damaged.

Problem: Face is bent, needle is bent, glass is broken, etc.

Solution: Replace or have repaired.

Other problems may occur, but these are the most common regulator-related problems and situations.



Changing a CO₂ tank (Fig. 6.12)

- 1) **Turn off the CO₂ Tank (D)**
 - a) Turn drum valve (A) clockwise until it stops.
- 2) **Turn off the Toggle Shut Off Valve (I)**
 - a) Push toggle shut off valve (I) down to turn off gas to the system
 - b) Some toggle shut off valves have a valve switch; turn this switch 90°F to the left or right to turn off the gas line (M).
- 3) **Turn off the Primary CO₂ regulator (B)**
 - a) Make note of the current pressure on the primary CO₂ regulator low-pressure gauge (G). You will need to adjust this regulator back to this pressure when you turn the primary CO₂ regulator back on.
 - b) Insert and hold a bladed screwdriver in the set screw (C).
 - c) Then using the crescent wrench (K) turn the set screw lock nut (F) counterclockwise two turns to unlock the Set Screw (C).
 - d) Now turn the screw driver counterclockwise until the Low Pressure Gauge (G) reads 0 pounds.
- 4) **Remove the Primary CO₂ Regulator (B) from the CO₂ Tank (D)**
 - a) Using a large crescent wrench (K) or CO₂ key wrench (L) turn the regulator coupling nut (E) counterclockwise and remove regulator.
- 5) **Unhook the CO₂ tank safety chain (J)**
- 6) **Check the CO₂ tank safety inspection date (O)**
 - a) Always check the test date on the cylinder neck (O) before installation. If it is over 5 years old, do not use and return the tank to the supplier.
- 7) **Exchange empty with new CO₂ tank and secure new tank with the safety chain (J)**
- 8) **Remove dust cap on new CO₂ tank**
 - a) Point tank dust cap away from you.
 - b) Now quickly open and close the drum valve (A) to remove dust cap and clear any dust from the new CO₂ tank outlet.
- 9) **Inspect the primary CO₂ regulator's built-in CO₂ O-ring**
 - a) Assure that the built-in O-ring located in the Regulator coupling nut (E) is in place and not damaged; replace if needed.
 - b) If regulator does not have a built-in o-ring, replace the old fiber or plastic washer with a new one.
- 10) **Reattach the Primary CO₂ Regulator (B)**
 - a) With O-ring or washer in place, use your wrench (K) or (L) to tighten the primary CO₂ regulator (B) to CO₂ tank (D) by turning the regulator coupling nut (E) clockwise onto the drum valve (A),
- 11) **To turn CO₂ tank back on**
 - a) Turn the drum valve (A) counter clockwise until it stops.
- 12) **Reset low-pressure Gauge**
 - a) Using your bladed screw driver, turn the set screw (C) clock wise until the pressure gauge reads the original pressure.

- b) Hold the set screw (C) in place with screwdriver as you turn the set screw lock nut (F) clockwise until it is tight. This will keep set screw (C) in place and hold the selected pressure.
- 13) **Open the toggle shut-off valve (I)**
 - a) Lift toggle shut-off valve up, or turn it back parallel to turn gas back on.

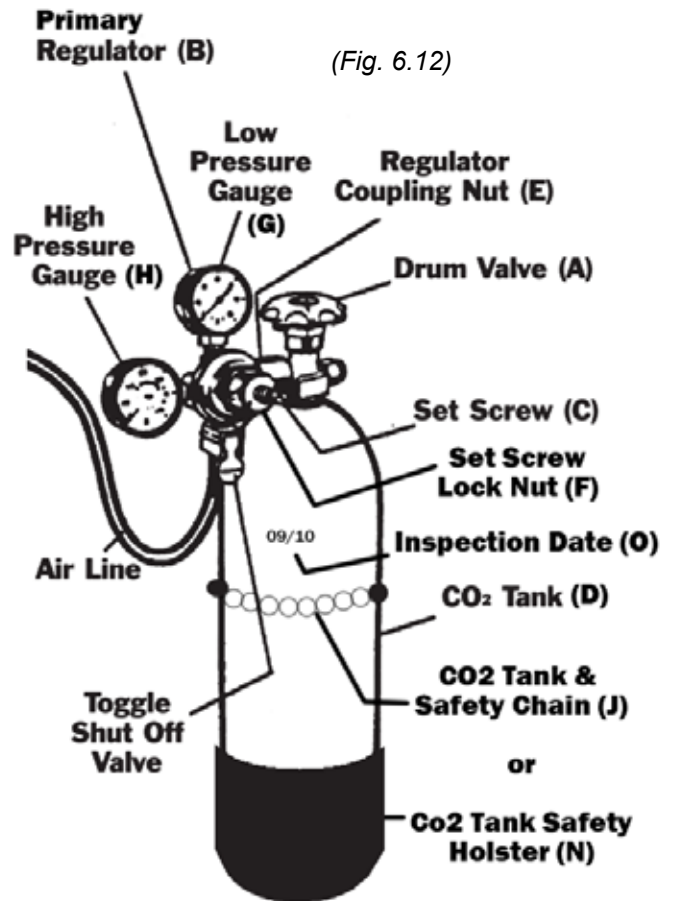

CO₂ Line

Vinyl CO₂ Line

5/16" ID vinyl CO₂ line/beer line is typically used on the low side of the primary regulator. It is not recommended for use on pressures of more than 35 lbs. (If you need more than 35 lbs a braided CO₂ line is recommended.) Use only a 5/16" ID that is safe at these pressures.

Braided CO₂ Line

For systems that run from 35 – 100 lbs use braided CO₂ line to prevent damage. Only use a braided line that is safe at these pressures.



5/16" Vinyl CO₂ Line



5/16" Braided CO₂ Line

Perlick CO₂ and Nitrogen Parts and Tools

Perlick carries a complete line of CO₂ parts, line and tools. Please refer to your current *Perlick Tapping Catalog* or visit www.perlick.com/store for order information. If you do not have your *Perlick Tapping Catalog* please call toll free at 800-558-5592, fax at 414-353-7069 or visit our web site at www.perlick.com.

CO₂ Regulators:

- 50-psig single and twin gauge primary regulators for:
 - a. Also for mixed gas
- Step down regulators
- Secondary regulators
 - b. 1-, 2-, 3- and 4-gauge manifolds
 - c. Non panel
 - d. Panel
 - e. Panel with locks
- 140 carbon dioxide primary regulators for soda
- Nitrogen Regulators
 - a. 50-psig single- and twin-gauge primary regulators
 - b. 125 psig high-pressure regulators
- CO₂ Nitrogen Blenders
- McDantim's TRUMIX
- Perlick Nitrogen/CO₂ Blender
- Nitrogen Generator – Beer Blast
- Beer Pumps
 - a. Beer pumps
 - b. CO₂ beer pump vent kits
- Gas Distribution Equipment
 - a. 1, 2, 3, 4, & 5 shut-off manifold with safety relief valves.
 - b. Shut-off valves
 - c. Safety relief valves
 - d. CO₂ "T's"
 - e. CO₂ nipples
 - f. Hose unions
 - g. CO₂ clamps
- Perlick CO₂ Line
 - a. Vinyl
 - b. Braided
- Perlick Tools
 - a. Tube cutter





Section 7

System Enhancements



7



Draught Beer Systems Enhancements

Stainless Steel Parts

For many years, suppliers have made metal parts for draught systems with chrome-plated brass. While chrome has no negative effect on beer quality and rarely wears away on the outside, the chrome coating on the inside wears out over time. Cleaning and beer flow eventually exposes the brass on the inside of these parts. This brings the beer in contact with the brass and picks up a metallic off-taste. Additionally, exposed brass is also difficult to clean due to its comparatively rough surface and wears the part out.

To avoid brass contact, brewers recommend stainless steel parts for draught dispense. In addition to being inert in contact with beer, they are easier to clean and thus help to maintain high-quality draught dispense. Manufacturers offer all faucets, shanks, tailpieces, hose unions, wall brackets and probes in stainless steel.

If your system already contains chrome-plated brass components, inspect the beer contact surfaces regularly for exposed brass and replace those components immediately when detected.

Special Couplers/Probes

There are many situations in which the standard "T" handle or Single handle coupler cannot be used to tap a keg and specially designed couplers are needed to tap the beer such as:

Keg boxes with short ceilings.

In this case a **Lo-Boy coupler for Single Domestic Kegs** is ideal. It has a low profile and the beer comes out of the side of the coupler instead of to the top so it can fit in a tighter keg box.

The beer line is constantly pinched when the beer line comes out of the top to the coupler

You can install a coupler that comes with a bent probe.

You can also retrofit a current tap with a **Bent Elbow** on the top of the coupler to keep the beer line from kinking on top of the coupler.

Imported keg couplers

Many imported beers use a variation of the Sankey tap (i.e., a longer probe tip) or their own unique coupler to tap their beer. Thus, you will need to use their import coupler to tap the beer.



Wall Brackets

It is recommended that all non direct draw systems use a wall bracket, to which the trunk line is attached. This takes the wear and tear off the trunk line and puts it on the jumper line from the keg to the wall bracket. Thus, if the jumper gets damaged it is easy to replace. If there were no wall bracket and the trunk line got damaged it is difficult to replace this line. The jumper line from the keg to the wall bracket should be the same ID as the trunk line used in the system.

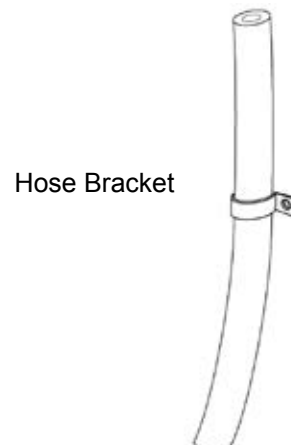
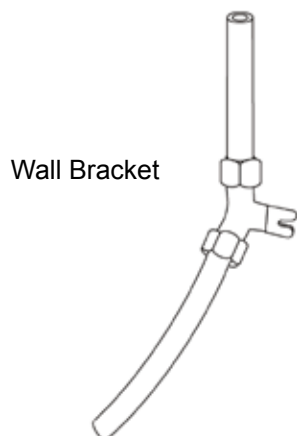

Kegs in Series

Many high-volume accounts connect their kegs in a series chain to meet peak capacity demands. Putting kegs in series allows two, three or up to 10+ kegs, of the same product, to empty without having to retap after each keg empties. The kegs in a series are named as follows:

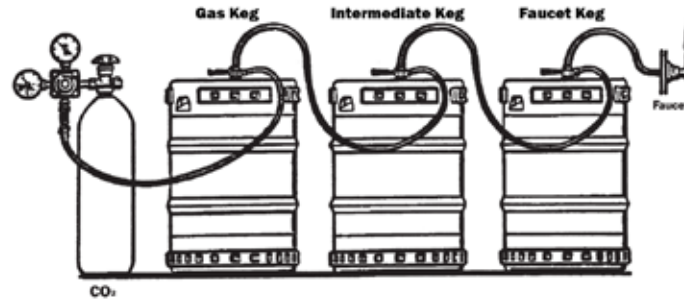

Faucet Keg – The keg that is hooked into the beer line going directly to the beer faucet

Gas Keg – The keg that is hooked directly to the tap to which the CO₂ is connected.

Intermediated Keg(s) – The keg(s) in the series that are tapped in between the faucet and gas keg.

How to Connect the Hardware to Connect Three Kegs in Series

1. First connect the CO₂ **(A)** line to the gas keg coupler **(B)** as usual
2. Next, build a jumper line and connect one end to top of the gas keg coupler probe **(C)** as follows:

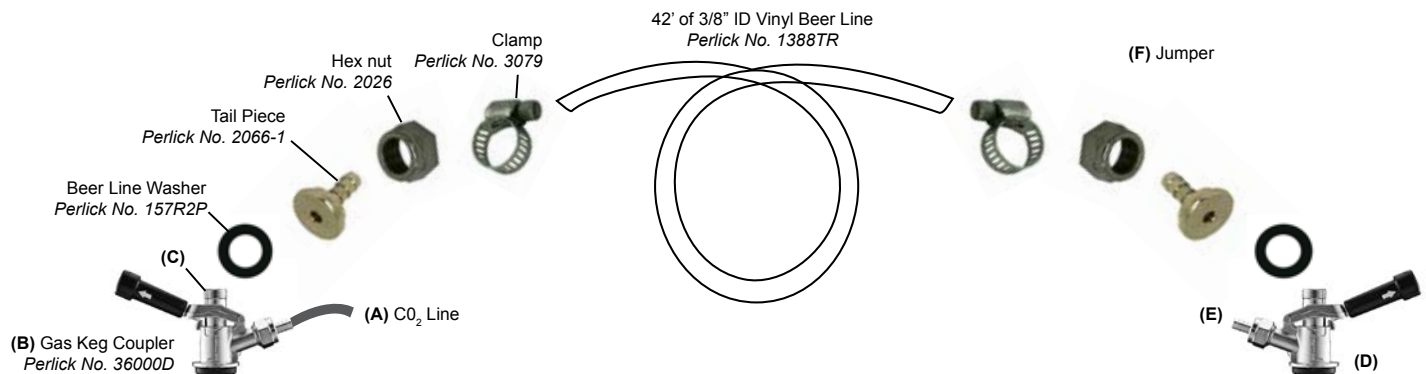

3. Now take another coupler **(D)**, to be used to tap the intermediate keg, and remove the CO₂ inlet **(E)**, including the Thomas valve.
4. Place a beer line washer in the hex nut of the other end of the gas keg jumper **(F)** and screw it onto the CO₂ inlet **(E)** of the intermediate keg's coupler.
5. Next, build another jumper line, per above, and connect one end to the top of the intermediate keg the other to the CO₂ inlet of the faucet keg coupler.
6. Now attach the beer line going to the faucet directly to the top of the faucet keg coupler probe.
7. Note: In a two keg series you will connect one end of the series jumper line to the top of the gas keg coupler and the other end to the CO₂ inlet on the faucet keg coupler.
8. Note: In a series of four or more kegs, make an additional jumper for each subsequent intermediate keg in the series and connect from the top of one coupler to the CO₂ inlet of the next intermediate keg in the series.

Beginning with the gas keg, lock, but do not tap, each succeeding coupler on the top of the keg to be tapped. Now return to the gas keg coupler and tap each keg in order from the gas keg, to each successive intermediate keg, and lastly the faucet keg.



How the Beer Flows through the Series System

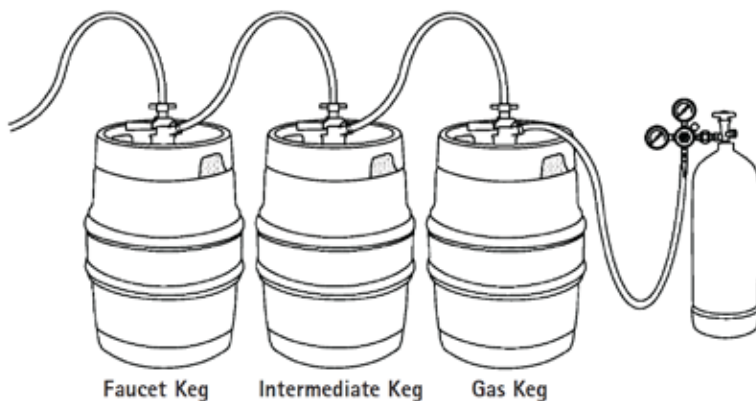

When the faucet is opened, the beer begins to run out of the faucet keg. The beer from the intermediate keg then begins to fill the faucet keg and in turn the beer from the gas keg begins to fill the intermediate keg. The gas from the CO₂ tanks begins to fill the gas keg. Thus, the beer in the gas keg will empty first. The beer in the intermediate keg (and any successive keg in order) will empty next, and the beer in the faucet keg will empty last.

Number of Kegs to Use in a Series

A series arrangement should only be used in accounts that will “turn,” or empty kegs rapidly. There should never be more kegs on tap, in the series, than the account uses in a week. The entire series system needs to completely empty at least once a week to keep the beer fresh. Failure to empty the series completely leaves old beer in the system, causing off taste, cloudiness and can lead to foaming problems.

Beer “Ys”

A beer Y may be used to split the beer from one keg to two faucets as follows:



Make sure that the ID of the bore is at least 5/16” ID.

Beer Switches

A beer switch is a highbred of the “Y” and can be used, as the “Y” above, to feed two faucets and, in addition, have the ability to turn off the supply of beer to either faucet.

Additionally, beer switches can be used in conjunction with kegs in a series to improve keg rotation as follows. Here a four keg series has been converted to two kegs on either side of a beer switch. This allows the beer to run out every two kegs instead of every four kegs and we still have the same amount of beer on tap.

Kegs in Series to a Beer Switch



This will allow the beer on one side to run out completely, and then the other side is turned on allowing for fresh beer in accounts that want more beer on tap but do a moderate amount of volume.



Beer Fobs and Sensors

It is desirable for systems with a long beer line to have the beer shut off as soon as the keg goes empty in order to keep the volume of beer in the beer line from going all to foam (i.e., waste). The following devices can be installed to prevent the beer from going to foam when the keg empties.

Beer Fobs

A beer FOB, such as the TruPour Wall Mount Cam Lever FOB Detector, senses when the keg goes empty and will shut off the supply of the beer to the trunk line, saving that beer and increasing profitability.



*TruPour Wall Mount Cam
Lever FOB Detector
Part No. 43844C*

Keg Sensors

Likewise a keg sensor, such as either one of the sensors below, can be used to sense when the keg goes empty and it will then shut off the flow of beer to the trunk line.

- Perlick EKS Coupler with integral empty keg sensor (#36000F)
- Perlick Universal Empty Keg Sensor

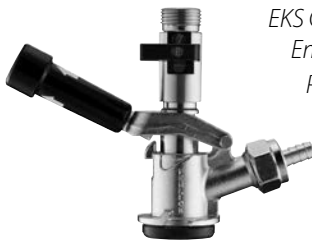

*EKS Coupler w/ Integral
Empty Keg Sensors
Part No. 36000F*



*Universal
Empty Keg Sensor
Part No. 43739A*

Double Shanks

In some accounts that draw pitchers and glasses of beer, the beer may come out too fast for a glass of beer or too slow for a pitcher of beer. One solution to this situation is the double shank or double standard.

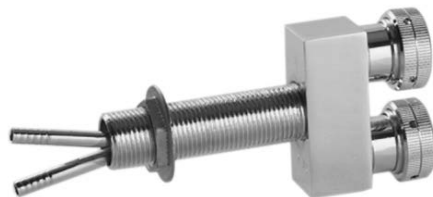

*Double Faucet Shank
Part No. 63795-2
(shown in chrome, also available in
brass, in 2", 4" and 6" sizes)*

One keg can be hooked to both faucets. Each side to the double shank or standard is set up to draw a glass of beer, and when a pitcher is needed both faucets can be opened at the same time allowing for a quick pour of the pitcher.

The double shank can also be used in a barrel head or air exchange box to replace one shank with two shanks allowing for the addition of another beer without having to drill in another hole in the face of the barrel head or air exchange box.



Notes





Section 8

Systems Balancing



8



Draught Beer Systems Balancing

All beer contains dissolved carbon dioxide from the brewing process. The brewer goes to great effort to produce their beer and have it presented to the consumer in its best light.

If the beer does not flow correctly through the system then all the effort put into the beer at the brewery can go for naught. For beer servers, the CO₂ in the beer can be both a blessing and a curse. Ideally, we deliver beer to the consumer's glass while maintaining its CO₂ content. When this happens, the beer pours "clear" without foaming and the bartender can easily create a pleasing head on the beer without waste.

But in many draught systems the bartender is faced with foamy beer as it comes out the faucet and the server overflows the glass trying to get a decent pour. The beer quality suffers and in turn the retailer's profitability suffers because of the wasted beer.

The goal is to put beautiful, high-quality beer in the glass and maximize retailer profit. To do this, we must control the flow of beer from the faucet and make sure that the system draws properly. To reach this goal we must balance the system.

What is draught system balance?

A draught beer system is in balance when:

| | | |
|--------------------------------------|------------|---|
| 1) Applied Gauge Pressure on the keg | equals the | 2) Systems Resistance to the beer flow. |
|--------------------------------------|------------|---|

This sounds like science, and it is, and we will make this simple as you will see below:

1) Applied Gauge Pressure

What is the applied gauge pressure and how is it calculated?

The applied gauge pressure is the pressure that is applied to the keg when it is packaged and is expressed in pounds per square-inch-gauge abbreviated as "psig," or often just "psi." The applied pressure is dependent upon the following three factors:

- A) The volume of CO₂ in the keg
- B) The temperature of the beer in the keg and
- C) The elevation where the beer is tapped

Let's look at the dynamics of these three factors and the effect they have on the applied gauge pressure.

A. Volumes of CO₂ in the Keg

Brewers measure beer carbonation in volumes of CO₂. A typical value might be 2.7 volumes of CO₂ meaning, literally, that 2.7 keg's worth of uncompressed CO₂ has been squeezed/dissolved into one keg of beer.

2.7 kegs of CO₂ squeeze into 1 keg (right)

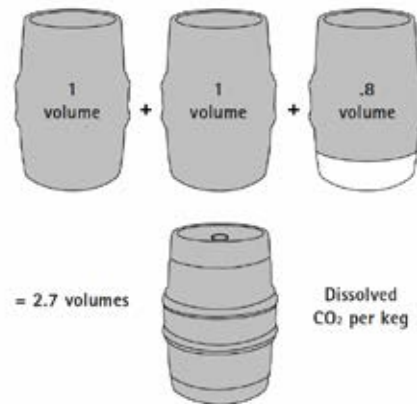

Each brewer determines the volumes of CO₂ they want in each brand of beer, for it influences the overall character and taste of the draught beer. The more volumes of CO₂ in a keg the higher the applied gauge pressure on the beer. Carbonation levels in typical beers run from 2.2 to 2.8 volumes of CO₂, but values can range from as little as 1.2 to as high as 4.0 in specialty beers. The chart below shows the applied gauge pressure of one beer containing 2.6 volumes of CO₂ and one beer containing 2.8 volumes of CO₂ that are both packaged at sea level at 38°F.

Applied Gauge Pressure

| | Temperature of beer when packaged | Volumes of CO ₂ | Applied Gauge Pressure |
|--------|-----------------------------------|----------------------------|------------------------|
| Beer 1 | 38°F | 2.6 | 12.4 psig |
| Beer 2 | 38°F | 2.8 | 14.5 psig |



Thus, you can see that the more volumes of CO₂ that the brewer puts in the keg the higher the applied gauge pressure. If a keg of Beer 1 was delivered to a retail account, where the keg temperature will be kept at a cooler temperature of 38°F, we would set the applied gauge pressure on the low-pressure side of the regulator at 13.0 psig (always round up). Likewise we would set the applied gauge pressure on the low-pressure side of the regulator feeding Beer 2 to 15 psig (always round-up). This would keep the natural CO₂ in the keg from going flat or over carbonating.

B. Temperature of Beer in Keg

Let's see how the temperature of the beer in the keg affects the applied gauge pressure. To check the temperature of the beer in the keg you can do one of the following:

1. Use a Perlick Single Valve (Handle) Test coupler which will measure the temperature and applied gauge pressure in the keg.
2. Use a surface reading thermometer, which has a probe tip that you push against the outside of the keg to read the keg temperature.
3. A pocket (dial) thermometer (Perlick part no. 1595B) can test the temperature of a closed container, such as an unopened can of soda that is sitting by the keg. Purchase or request the retailer's permission to open the container to take the temperature. Go to Appendix G to see how to calibrate the dial thermometer to assure that it is reading correctly.



Pocket Thermometer
Part No. 1595B



Single Valve Test Coupler
Part No. 26159C

As the temperature of the beer increases or decreases the pressure inside the keg, the applied gauge pressure increases and decreases respectively. It turns out that for every 2°F the beer temperature goes up or down the corresponding gauge pressure goes up or down approximately 1 psig. Thus we can come up with a quick reference chart that will tell us at what pressure we should set the low pressure gauge regulator feeding each beer based on the volumes of CO₂ and the temperature of the beer.

Chart 1—CO₂ Applied Gauge Pressure

Based the Beer's Volumes of CO₂ and Temperature (See Appendix B for more info)

| Vol. CO ₂ | 2.1 | 2.2 | 2.3 | 2.4 | 2.5 | 2.6 | 2.7 | 2.8 | 2.9 | 3.0 | 3.1 |
|----------------------|------|------|------|------|------|------|------|------|------|------|------|
| Temp°F | psig | psig | psig | psig | psig | psig | psig | psig | psig | psig | psig |
| 33 | 5.0 | 6.0 | 6.9 | 7.9 | 8.8 | 9.8 | 10.7 | 11.7 | 12.6 | 13.6 | 14.5 |
| 34 | 5.2 | 6.2 | 7.2 | 8.1 | 9.1 | 10.1 | 11.1 | 12.0 | 13.0 | 14.0 | 15.0 |
| 35 | 5.6 | 6.6 | 7.6 | 8.6 | 9.7 | 10.7 | 11.7 | 12.7 | 13.7 | 14.8 | 15.8 |
| 36 | 6.1 | 7.1 | 8.2 | 9.2 | 10.2 | 11.3 | 12.3 | 13.4 | 14.4 | 15.5 | 16.5 |
| 37 | 6.6 | 7.6 | 8.7 | 9.8 | 10.8 | 11.9 | 12.9 | 14.0 | 15.1 | 16.1 | 17.2 |
| 38 | 7.0 | 8.1 | 9.2 | 10.3 | 11.3 | 12.4 | 13.5 | 14.5 | 15.6 | 16.7 | 17.8 |
| 39 | 7.6 | 8.7 | 9.8 | 10.8 | 11.9 | 13.0 | 14.1 | 15.2 | 16.3 | 17.4 | 18.5 |
| 40 | 8.0 | 9.1 | 10.2 | 11.3 | 12.4 | 13.5 | 14.6 | 15.7 | 16.8 | 17.9 | 19.0 |
| 41 | 8.3 | 9.4 | 10.6 | 11.7 | 12.8 | 13.9 | 15.1 | 16.2 | 17.3 | 18.4 | 19.5 |
| 42 | 8.8 | 9.9 | 11.0 | 12.2 | 13.3 | 14.4 | 15.6 | 16.7 | 17.8 | 19.0 | 20.1 |

C. Elevation at Which the Keg is Tapped

The third factor that affects the applied gauge pressure is the elevation at which the keg is served. The applied gauge pressure on the keg goes up or down 1 psig for every 2,000-ft. that the keg goes up or down in elevation above sea level. Thus, it is important to know the elevation of the account in which you are tapping the beer so you can set the proper applied pressure on the low-pressure side of the regulator feeding the keg.

Example

You are installing draught beer in an account in your market. The beer:

- Has 2.8 volumes of CO₂ as confirmed by the brewer
- Is being installed in a ski area located at an elevation of 10,000 ft. above sea level
- Temperature in the keg is 36°F



What is the correct applied gauge pressure for this account?

- Go to Chart 1–CO₂ Applied Gauge Pressure and go across the top of the chart to 2.8 volumes.
- Now, drop down this column to the box that intersects with the 36°F row to find that the applied gauge pressure at sea level, i.e., 13.4 psig.
- Next, add in 1-lb. of pressure per 2,000-lb. of elevation above sea level as follows:

| | | |
|---|--------------|-------------|
| Elevation | 10,000 | ft. |
| Feet divided by | <u>2,000</u> | <u>ft.</u> |
| Equals | 5.0 | psig |
| Add this to the gauge pressure at sea level | <u>13.4</u> | <u>psig</u> |
| This equals ideal applied gauge pressure for this system | 18.4 | psig |
| It is recommended that you round up the applied gauge pressure to the next whole number; so apply | 19.0 | psig |

Applied Gauge Pressure Summary

Use this process to determine the ideal applied gauge pressure in the account that you are servicing.

2) Systems Resistance

What is systems resistance and how is it calculated?

Systems Resistance is the resistance/friction of the flow of the beer as it moves through the keg to the faucet. The resistance comes from the three key factors:

- A. The parts** in the system that the beer flows through
- B. Gravity** pulls down on the beer in the beer Line
- C. The Beer Line** itself

A. The Parts in the System

Each part (couplers, tail pieces, beer switches, beer “Y’s”, shanks, tube elbows, hose unions, shank & bent tube assemblies, faucets, etc.) in which the beer comes in contact creates a slight amount of resistance to the beer flow. The resistance for most of these parts is very small and has little impact on the flow of the beer through the system.

B. Gravity

Vertical Rise The force of gravity pulls down on the beer as it goes from the bottom of the keg through the faucet. If the beer rises from the bottom of the keg to the height of the faucet then the beer is slowed down by gravity giving the system resistance to flow. This is called vertical rise.

In the system to the right (*Fig. 8.1*) the vertical rise is 4-ft (i.e. the height from the bottom of the keg to height of the faucet). The total resistance from the vertical rise is 4-ft times 0.5-ft per foot or +2.0-lbs of resistance from gravity in these systems.

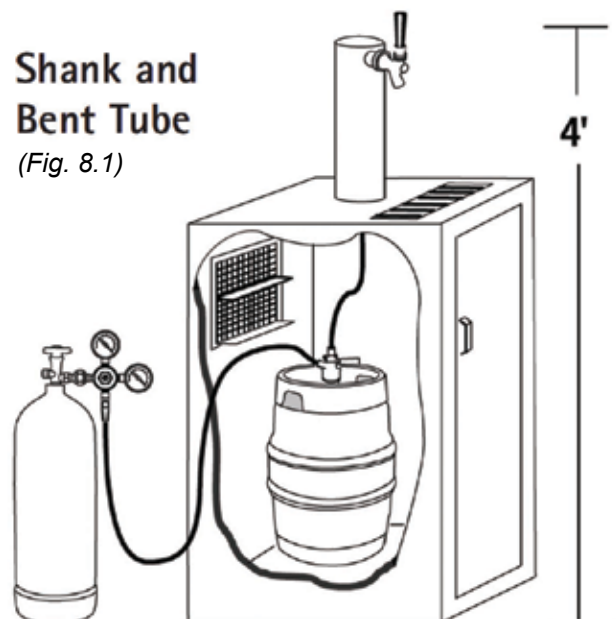

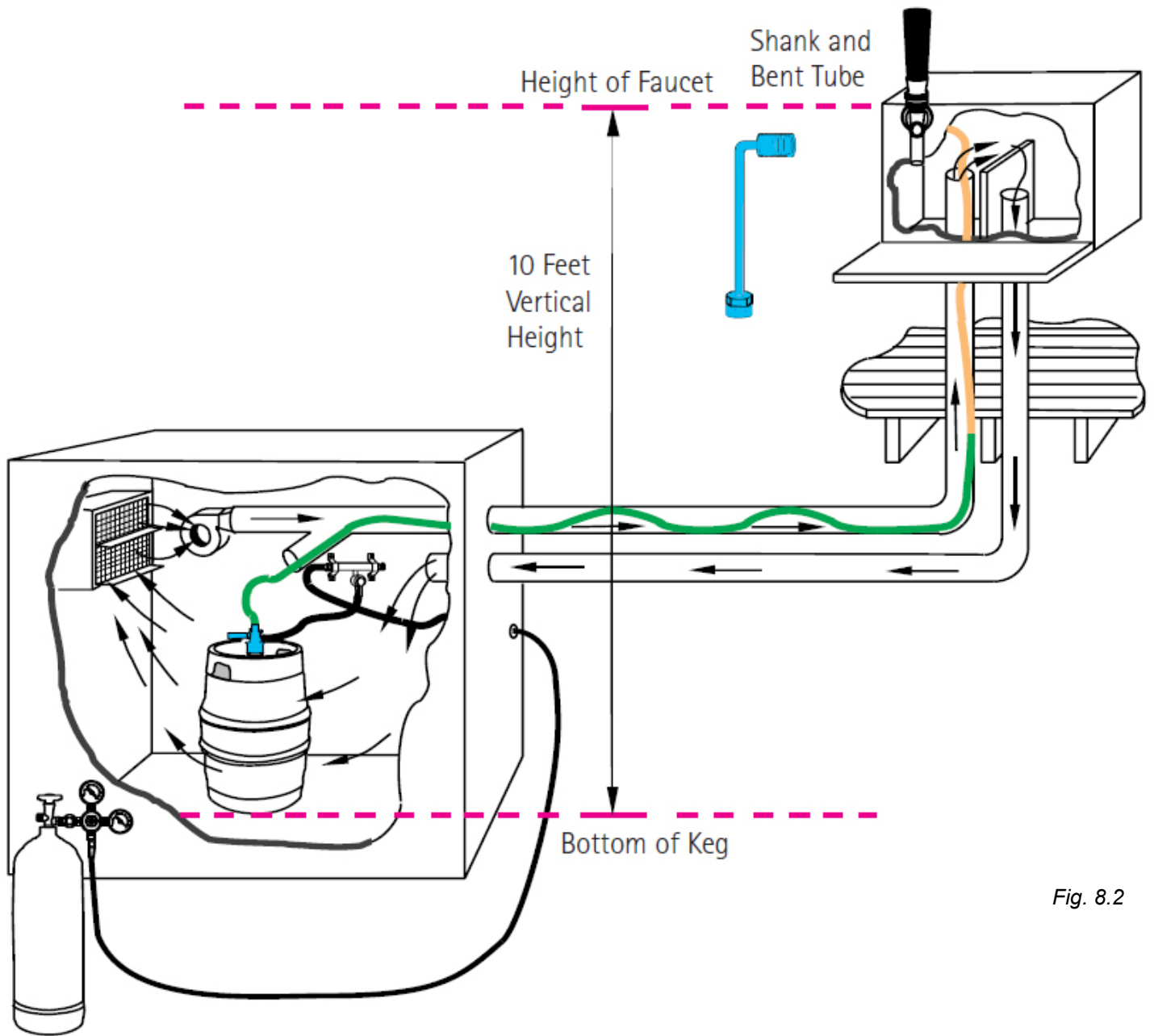

Fig. 8.2

Vertical Drop / Fall

The force of gravity pulls down on the beer as it goes from the bottom of the keg through the faucet. If the beer drops from the bottom of the keg to the height of the faucet, then gravity speeds up the flow of beer out of the faucet. This is called vertical drop or fall (Fig. 8.3, pg. 62). To counter the effect of the vertical fall we must add more resistance to the system to keep it in balance.



Vertical Drop / Fall (cont.)

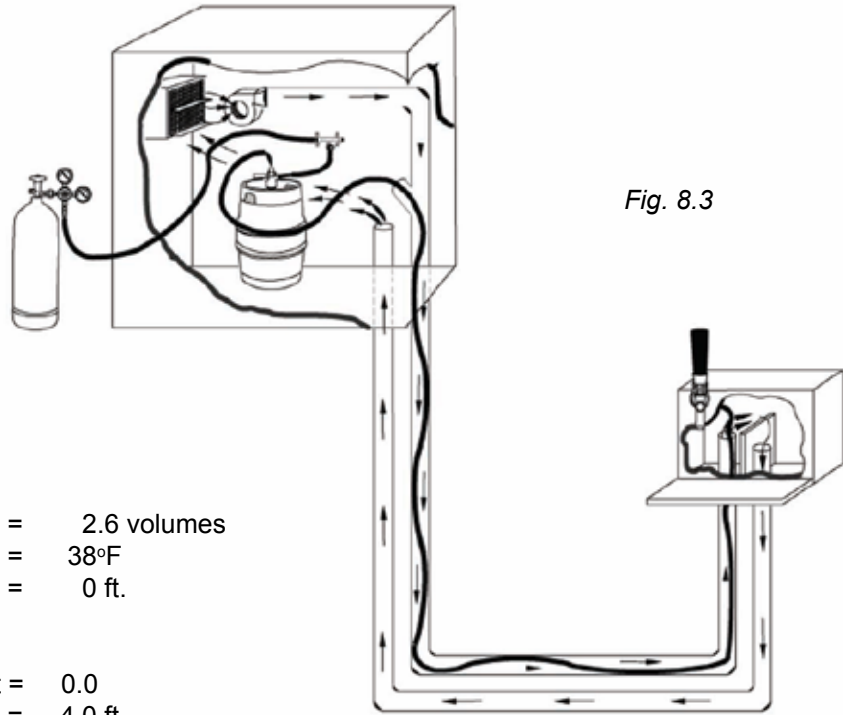

Fig. 8.3

System Parameters:

Applied Gauge Pressure Variables:

- CO₂ volumes in the beer = 2.6 volumes
- Temperature of beer in the keg = 38°F
- Account elevation = 0 ft.
- above sea level

Systems Resistance Variables:

- Parts – None that have any impact = 0.0
- Gravity – vertical fall = 4.0 ft.
- Beer Line – length = 25.0 ft.

The resistance of gravity is +.5-lbs. per foot for vertical rise and -.5-lbs per ft. for vertical fall. Remember that the vertical rise or fall is based on the height of the faucet compared to the bottom of the keg as indicated above.

In the example above the faucet is located 4 ft. below the bottom of the keg. Thus, this system has a vertical drop of 4 ft. Using the Vertical Drop Chart, on the right. Below, we see that a vertical drop of 4 ft. has a resistance of -2.0-lbs, meaning that gravity speeds up the flow rate of the beer in this system. Thus, we will need to add an additional 2-lbs. of resistance to balance this system to slow the flow rate down.

Use the charts below to determine the number of pounds of Systems Resistance from vertical rise or vertical drop.

| Vertical Rise * | | | |
|------------------------------------|--------------------|---------------------------|--------------------|
| # of Ft. of Vertical Rise | lbs. of Resistance | # of Ft. of Vertical Rise | lbs. of Resistance |
| 1 | 0.5 | 11 | 5.5 |
| 2 | 1.0 | 12 | 6.0 |
| 3 | 1.5 | 13 | 6.5 |
| 4 | 2.0 | 14 | 7.0 |
| 5 | 2.5 | 15 | 7.5 |
| 6 | 3.0 | 16 | 8.0 |
| 7 | 3.5 | 17 | 8.5 |
| 8 | 4.0 | 18 | 9.0 |
| 9 | 4.5 | 19 | 9.5 |
| 10 | 5.0 | 20 | 10.0 |
| *Formula: Ft. of Rise divided by 2 | | | |

| Vertical Drop * | | | |
|------------------------------------|--------------------|---------------------------|--------------------|
| # of Ft. of Vertical Drop | lbs. of Resistance | # of Ft. of Vertical Drop | lbs. of Resistance |
| 1 | -0.5 | 11 | -5.5 |
| 2 | -1.0 | 12 | -6.0 |
| 3 | -1.5 | 13 | -6.5 |
| 4 | -2.0 | 14 | -7.0 |
| 5 | -2.5 | 15 | -7.5 |
| 6 | -3.0 | 16 | -8.0 |
| 7 | -3.5 | 17 | -8.5 |
| 8 | -4.0 | 18 | -9.0 |
| 9 | -4.5 | 19 | -9.5 |
| 10 | -5.0 | 20 | -10.0 |
| *Formula: Ft. of Drop divided by 2 | | | |



C. Beer Lines

The beer line also provides a resistance for each foot the beer travels through it. Beer lines may be made from vinyl, polyethylene, barrier tubing and even stainless steel. Each type and diameter has a different Systems Resistance (stated as “restriction”) to beer flow as shown in the following charts.

(Note: These charts provide an example only. Please consult your equipment manufacturer for specific values of their beer lines.)

Vinyl Beer Line

| Resistance Values for Vinyl Beer Line | | |
|---------------------------------------|---------------------------|----------------|
| ID | Resistance (lbs. per ft.) | Volume per ft. |
| 3/16" | 3.00 | 1/6 oz. |
| 1/4" | 0.85 | 1/3 oz. |
| 5/16" | 0.40 | 1/2 oz. |
| 3/8" | 0.20 | 3/4 oz. |
| 1/2" | 0.025 | 1&1/3 oz. |

Polyethylene Beer Line

| Resistance Values for Polyethylene Beer Line | | |
|--|---------------------------|----------------|
| ID | Resistance (lbs. per ft.) | Volume per ft. |
| 3/16" | 2.2 | 1/6 oz. |
| 1/4" | 0.5 | 1/3 oz. |
| 5/16" | 0.1 | 1/2 oz. |
| 3/8" | 0.07 | 3/4 oz. |

All of the beer line is vinyl. To calculate the resistance in the beer line do the following:

| | |
|---|----------------------------------|
| The beer line jumper line from the coupler to wall bracket is: | 5.0 ft. of 5/16 in. vinyl |
| The beer line from the wall bracket to the hose union to the 3/16 beer line is: | 18.5 ft. of 5/16 in. vinyl |
| The beer line from the hose union to the faucet shank is: | <u>1.5 ft. of 3/16 in. vinyl</u> |
| This gives us a beer line that is a total of: | 25.0 ft. |

To calculate the total resistance from this 25-ft. beer line, multiply the resistance per foot of each line times the number of feet of line as follows:

| Line | ID of line | Length of Vinyl Line | Resistance per ft. from chart above | Equals the resistance in the line |
|-----------------|-------------|----------------------|-------------------------------------|-----------------------------------|
| Jumper (E) | 5/16" | 5.0 ft. | 0.40 #s per ft. | 2.0 # |
| Trunk (D) | 5/16" | 18.5 ft. | 0.40 #s per ft. | 7.4 # |
| Choker Line (F) | 3/16" | 1.5 ft. | 3.00 #s per ft. | 4.5 # |
| Total Beer Line | Combination | 25.0 ft. | - | 13.9 # |

Thus, by knowing the type, length and ID of the beer line, we can calculate the beer line’s resistance in the system.

When building a beer line it is recommended that you use the smallest ID trunk line to go the distance that the system requires. The larger the ID of the beer line the more beer you have in the beer line; where the beer is most susceptible to encountering drawing problems.



Beer System Resistance Made Easy

Dispense Goals

The dispense goal of a balanced draught system is to delivers clear-pouring beer at the rate of 1 gal./min, or 2 oz./sec. This means it takes about eight seconds to fill a pint (16 oz.) glass.

A draught beer system is in balance when

| | | |
|---|-------------------|---|
| 1) Applied Gauge Pressure on the keg | equals the | 2) Systems Resistance to the beer flow |
|---|-------------------|---|

Say we are putting a new vinyl beer line in the forced air system pictured below

System Parameters:

Applied Gauge Pressure Variables:

- CO₂ volumes in the beer = 2.8 volumes
- Temperature of beer in the keg = 34°F
- Account elevation = 2,000 ft.
above sea level

Systems Resistance Variables:

- Parts – none that have any impact = 0.0
- Gravity – vertical rise = 10.0 ft.
- Beer Line – length = 22.0 ft.

Let’s put our systems balancing knowledge to work. We know, to have a balanced system, we need to determine the:

| | | |
|----------------------------------|-------------------|---|
| 1) Applied Gauge Pressure | equals the | 2) Systems Resistance to the beer flow |
|----------------------------------|-------------------|---|

So first we must calculate the ideal Applied Gauge Pressure based on the system facts above.

Chart 1–CO₂ Applied Gauge Pressure

Based on the Beer’s Volumes of CO₂ and Temperature (See Appendix B for more info)

| Vol. CO ₂ | 2.1 | 2.2 | 2.3 | 2.4 | 2.5 | 2.6 | 2.7 | 2.8 | 2.9 | 3.0 | 3.1 |
|----------------------|------|------|------|------|------|------|------|------|------|------|------|
| Temp°F | psig | psig | psig | psig | psig | psig | psig | psig | psig | psig | psig |
| 33 | 5.0 | 6.0 | 6.9 | 7.9 | 8.8 | 9.8 | 10.7 | 11.7 | 12.6 | 13.6 | 14.5 |
| 34 | 5.2 | 6.2 | 7.2 | 8.1 | 9.1 | 10.1 | 11.1 | 12.0 | 13.0 | 14.0 | 15.0 |
| 35 | 5.6 | 6.6 | 7.6 | 8.6 | 9.7 | 10.7 | 11.7 | 12.7 | 13.7 | 14.8 | 15.8 |
| 36 | 6.1 | 7.1 | 8.2 | 9.2 | 10.2 | 11.3 | 12.3 | 13.4 | 14.4 | 15.5 | 16.5 |
| 37 | 6.6 | 7.6 | 8.7 | 9.8 | 10.8 | 11.9 | 12.9 | 14.0 | 15.1 | 16.1 | 17.2 |
| 38 | 7.0 | 8.1 | 9.2 | 10.3 | 11.3 | 12.4 | 13.5 | 14.5 | 15.6 | 16.7 | 17.8 |
| 39 | 7.6 | 8.7 | 9.8 | 10.8 | 11.9 | 13.0 | 14.1 | 15.2 | 16.3 | 17.4 | 18.5 |
| 40 | 8.0 | 9.1 | 10.2 | 11.3 | 12.4 | 13.5 | 14.6 | 15.7 | 16.8 | 17.9 | 19.0 |
| 41 | 8.3 | 9.4 | 10.6 | 11.7 | 12.8 | 13.9 | 15.1 | 16.2 | 17.3 | 18.4 | 19.5 |
| 42 | 8.8 | 9.9 | 11.0 | 12.2 | 13.3 | 14.4 | 15.6 | 16.7 | 17.8 | 19.0 | 20.1 |

Follow these Steps to Determine the Ideal Applied Gauge Pressure for this Account

1. Determine the applied gauge pressure at sea level.

You do this by going across the top of this chart to the 2.8 column and dropping down this column until we intersect with the to the 36°F row to find that the applied gauge pressure at sea level 13.4 psig

2. Adjust for the elevation.

As you recall we add 1-lb. of gauge pressure for every 2,000-ft. we go up in elevation. Thus, with the elevation of the account divided by one pound per 2,000-ft. we would add 1.0 psig to the 13.4 lbs. and find that applied gauge pressure for this account would be14.4 psig.

We have now determined the:

| | | |
|----------------------------------|-------------------|---|
| 1) Applied Gauge Pressure | equals the | 2) Systems Resistance to the beer flow |
|----------------------------------|-------------------|---|



Now to balance the system we need to calculate the:

| | | |
|----------------------------------|------------|--|
| 1) Applied Gauge Pressure | equals the | 2) Systems Resistance to the beer flow. |
|----------------------------------|------------|--|

To balance this system we must have 14 lbs. of Systems Resistance from the following:

- Parts in the system that have resistance
- Gravity – Vertical Rise or Vertical Drop
-In this account we have Vertical Rise for the faucet is higher than the bottom of the keg.
- The Resistance from the Beer Line

Follow these Steps to Determine the Systems Resistance

1) Resistance from Parts

This system has a shank behind the faucet and the other parts have little resistance so we have 0 lbs. of resistance from the parts in the system.

2) Gravity

It is 10 ft. from bottom of the keg up to the height of the faucet, so we have vertical rise in this account. From the Vertical Rise Chart, look down **the # of ft. of Vertical Rise** column and find the number of feet of vertical rise, in this case 10 ft. Read the number to the immediate right to find the number of pounds of resistance for this account.

| Vertical Rise * | | | |
|--------------------------|--------------------|--------------------------|--------------------|
| # of Ft of Vertical Rise | lbs. of Resistance | # of Ft of Vertical Rise | lbs. of Resistance |
| 1 | 0.5 | 11 | 5.5 |
| 2 | 1.0 | 12 | 6.0 |
| 3 | 1.5 | 13 | 6.5 |
| 4 | 2.0 | 14 | 7.0 |
| 5 | 2.5 | 15 | 7.5 |
| 6 | 3.0 | 16 | 8.0 |
| 7 | 3.5 | 17 | 8.5 |
| 8 | 4.0 | 18 | 9.0 |
| 9 | 4.5 | 19 | 9.5 |
| 10 | 5.0 | 20 | 10.0 |

*Formula: # of Ft. of Rise divided by 2

The answer is **5.0 lbs**
 Sub total of parts plus gravity is **5.0 lbs**

3) Beer Line

Now we have to find the proper amount of resistance we need in the beer line to balance the system. We see above that we need 14.4 total pounds of systems resistance to balance the system applied gauge pressure of: 14.4 psig. We have 5.0 lbs. of systems resistance from the parts and gravity so the rest must come from the beer line: - 5.0 psig. We must build a 22-ft. beer line that has 9.6-lbs. of systems resistance in it.

The easiest way to do this is to use 1/4 ID Barrier beer line for forced air systems up to 25-ft. long, and 5/16-in. ID Barrier for forced air systems 25 to 50 ft.

If we take 22 ft. of 1/4 ID Barrier beer line @ a systems resistance of 0.3 pounds of resistance per ft. = - 6.6 #s
 of systems resistance in it. Thus we still need 3.0 #s
 of additional systems resistance. The additional systems resistance in the beer line will come from the 3/16-in. ID vinyl chocker as follows. 3/16" ID vinyl has 3.0-lbs. of resistance per foot and we need 3 lbs. of additional systems resistance, so if we add on a foot of 3/16-in. ID vinyl beer line we will have of additional systems resistance. - 3.0 #s
= 0.0 #s

The system is now in balance as the

| | | |
|---|------------|--|
| 1) Applied Gauge Pressure on the keg | equals the | 2) Systems Resistance to the beer flow. |
|---|------------|--|

This will give us a flow rate of about 128 oz. per minute. While this flow rate is acceptable in some accounts, it may be too fast for others. If you need to slow the flow-rate down just add 3 ft. of 3/16 vinyl to the line. If this is too slow, then simply cut off 6 in. of the 3/16" ID beer line, at a time, until the flow rate is acceptable to the retailer.



Problems Created by Systems That Are out of Balance

Both over-restrictance and under-restrictance will cause drawing problems as follows:

Over-restrictance looks like:

1. The beer runs slowly.
2. The beer doesn't fill the faucet which causes an uneven pour.
3. The beer swirls out of the faucet and breaks up causing foaming problems.

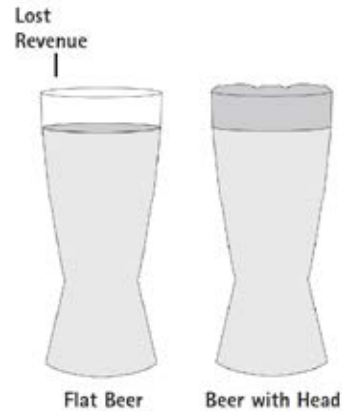

How to solve over-restrictance problems:

1. Check to make sure that beer is tapped in and all CO₂ valves are open.
2. Check for proper CO₂ setting. Adjust if pressure is incorrect according to beer temperature.
3. Change faucet if burrs are apparent on present faucet.
4. If the beer still runs too slowly, rebalance the system, installing the correct size and amount of beer line.

Under-restrictance:

When a beer system is under restricted, the beer is leaving the beer line faster than the keg can fill the line. This creates a vacuum in the system, resulting in a low pressure problem in both the beer line and the keg. This is called a recovery problem. Thus, as we saw earlier in the CO₂ section, this causes the CO₂ to come out of the beer line, collect in pockets of foam at the high spots in the system and causes drawing problems.

Under-restrictance looks like (Fig. 8.4):

1. The beer flows out of the faucet very fast.
2. Beer draws clean, but foams inside the glass.
3. Beer draws fast and clean, but too fast to satisfy the retailer.
4. When pouring a pitcher, beer alternates from running clear to foaming, i.e., recovery problem.
5. Foaming problems always occur during high volume usage, i.e., recovery problem.

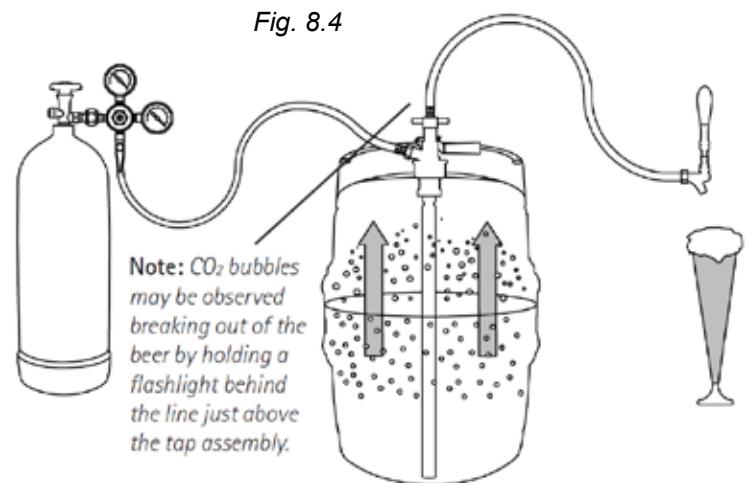

How to Solve Under-restrictance Problems:

1. Check CO₂ pressure to make sure it is correct. If not, reset it according to the ideal applied gauge pressure.
2. If the CO₂ is ok, add resistance.
3. If not okay, pull out the old lines and install new lines according to proper systems balancing numbers.
4. If system can't be removed (refrigerated line systems), resistance can be added between the keg and the wall bracket in the walk-in cooler.
5. For help on doing this, please call Perlick's toll free number at 800-558-5592.



Special Balancing Scenarios

Balancing Systems Where the Systems Resistance is Greater Than Applied Gauge Pressure

For example:

Say we have an account with the following givens:

System Parameters:

Applied Gauge Pressure Variables:

- CO₂ volumes in the beer = 2.6 volumes
- Temperature of beer in the keg = 34°F
- Account elevation = 0 ft.
- above sea level

Systems Resistance Variables:

- Parts – Shank and bent tube assembly = 1
- Gravity – Vertical **Rise** = 20.0 ft.
- Beer line – Length = 99.0 ft of 3/8" ID Barrier
- + 1.0 ft of 3/16" ID Vinyl
- Type of system = Glycol cooled so cannot pull in new lines

The Ideal Applied Gauge Pressure for this system would be

(from the Applied Pressure Chart) = 10.1 psig

Round up to = **11.0 psig**

The Systems Resistance would be

| | |
|--------------------------------|---|
| Parts | |
| 1 Shank and bent Tube Assembly | = 3.00 pounds systems resistance |
| Gravity - Vertical Rise | |
| 20 ft X .5 # / foot | = 10.00 pounds systems resistance |
| 3/8" ID Barrier Trunk Line | |
| 99 ft X .06 # / foot | = 5.94 pounds systems resistance |
| 3/16" ID Vinyl Cocker Line | |
| 1 ft X 3.0 # / foot | = <u>3.00 pounds systems resistance</u> |

Total Systems Resistance in this System = 21.94 pounds systems resistance

This system is out of balance in that the Ideal Applied Pressure is 11.0 psig. and the Systems Resistance is 21.94 psig.

As we have seen, beer readily absorbs carbon dioxide. Any change in the applied gauge pressure of the CO₂ on a beer results in a change in the carbonation of the beer.

- If we put just 11.0-lbs. of pressure on the system, the beer would barely pour out of the faucet and would pour with foam.
- If we put 21.94-lbs. of straight CO₂ applied gauge pressure we would be in balance but we would over carbonate the beer in the keg.
- Thus, systems designers will determine the length of line and systems resistance needed in the system and then determine which type of beer line to use. In many systems, because of the length of the system and the vertical rise of the system are great, the systems resistance may be greater than the ideal applied gauge pressure required for the beer.

The question is ... How does one balance the system when the Applied Gauge Pressure is less than the Systems Resistance in order to get the flow rate we want but not over carbonate the beer?

We have a number of solutions:

1. Change the beer line, if possible, to a beer line with a smoother surface and /or larger ID.
2. Straight Nitrogen
3. Mixed Gas
4. Blended Gas
5. Beer Pump



Let's look at each of these options:

1) Change the beer line, if possible, to a beer line with a smoother surface.

Barrier tubing has a smoother inner wall than polyethylene or vinyl beer lines and poly lines are smoother than the inner wall of vinyl beer line.

For instance:

A 20-ft. run of 1/4-in. ID vinyl beer line adds (20-ft X .85-lbs. per foot) = 17.0-lbs. of systems resistance

A 20-ft. run of 1/4-in. ID poly beer line adds (20-ft X .50-lbs. per foot) = 10.0-lbs. of systems resistance

A 20-ft. run of 1/4-in. ID barrier tubing adds (20-ft X .30-lbs. per foot) = 6.0-lbs. of systems resistance

In the above example, we are using 3/8-in. ID Barrier tubing which is the smoothest type of line and it cannot be pulled out of the system and be replaced with a smoother line. Changing the beer line option will not work in this case.

2. Straight Nitrogen

Beer does not absorb nitrogen gas to any significant degree. This means we can apply nitrogen pressure to beer without changing the properties of the beer.

However, since there is no CO₂ in the nitrogen tank to maintain the balance of CO₂ in the keg, towards the end of the keg it may be somewhat flat if the beer is not used up quickly. Straight Nitrogen is available for purchase in 50-lbs. tanks but very expensive and can only dispense a few kegs before it runs out of gas. It is relatively hard to get in many locations.



*Beer Blast N² Generator
Part No. P200*

To lower the cost a retailer can purchase a Nitrogen Generator such as the Perlick Beer Blast (pictured above). This can be more cost effective if the account sells a high volume of draught beer. Contact Perlick at 1-800-558-5592 for information on how to purchase and installation of Nitrogen Generators.

3. Pre-Mixed Gas

In pre-mixed gas, CO₂ and Nitrogen are mixed in a gas tank cylinder and is a viable alternative in high volume accounts (10+ kegs per week). The basic mix of CO₂ to nitrogen is 25% CO₂ and 75% Nitrogen. Since this is not enough CO₂ to maintain the balance of CO₂ in the keg you may find that towards the end of the keg it may be somewhat flat if the beer is not used up quickly.

Contact your local CO₂ supplier for information on how to purchase pre-mixed gas for beer.

4. Blended Gas

Gas blenders are an ideal solution in that you have a separate supply of CO₂ and nitrogen. The two sources feed a blender box that mixes both gasses together in the appropriate mixture to maintain the natural carbonation in the beer. It also supplies the added pressure to push the beer through the system without over carbonating the beer. Those interested in the details of the proper mix of CO₂ and Nitrogen should go to Appendix C.

Two blenders of recommended as follows:

- a. The Perlick Nitrogen/ CO₂ Blender

- b. McDantim's Trumix CO₂-Nitrogen Blender

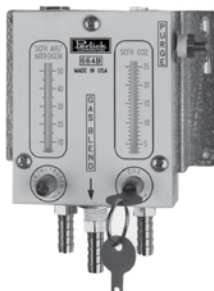

Part. No. 664B



Part No. 665

Contact Perlick at 1-800-558-5592 for information on how to purchase and have these blenders installed.



5. A Beer Pump

A beer pump is another great and cost effective solution to the problem expressed above. The beer pump is installed in the beer line in the cooler and actually pumps the beer through the system. The pump is run by CO₂ pressure and may be adjusted up or down to meet the flow rate demands of each individual beer. One pump is required for each beer line in the system.

Contact Perlick at 1-800-558-5592 for information on how to purchase and have these blenders installed.

6. Summary

If you try to achieve faster pours by increasing the CO₂ gas pressure you will create over-carbonated beer and thus, foam at the tap. With the above solutions you can adjust the flow rate of the beer by adjusting the mix to meet the needed flow rate. Your local draught technician can alter the applied gauge pressure to achieve this result. Once the technician makes the adjustments to the pressure gauges they should not be altered without consulting the technician.

Balancing Systems that have Kegs in Series

When balancing a system that has kegs in series, always balance the system as if there were only one keg in the system and just calculate the needed systems resistance from the faucet keg to the faucet.

Balancing Systems that have Beer “Ys” or Beer Switches with or without Kegs in Series

When balancing a system that has either beer “Ys” or beer switches, always balance the system as if there were only one keg in the system and just calculate the needed system’s resistance from either faucet keg. The two legs of the system that attach to the “Y” or beer switch will be the same length on either side.

Balancing Refrigerated Systems by Coiling Beer Line

Coiling line inside the cooler may sometimes be necessary. For example, in an enclosed glycol system that is running too fast, coiling may be appropriate. When rebalancing is impossible because of factory installation, adding extra beer line in the cooler may solve the drawing problem. The main trunk line should be attached directly to the top of a wall bracket. The keg should be attached to the bottom of another wall bracket with the coil being attached between the two wall brackets. Secure the coil to the wall using plastic ties. The amount of line to be used will be based on the amount of systems resistance in the system, subtracted from the ideal applied gauge pressure. For help on doing this please call Perlick’s toll free number **800-558-5592**.



Notes





Section 9

Special Events



9



Special Events Basic Equipment

There is a wide variety of systems designed to pour beer at special events. The choice of system depends on several variables: size of the event, duration of the event, and availability of electricity and CO₂.

For all the systems, a key element is keg temperature. Kegs should be kept 38°F or below by keeping the kegs refrigerated, iced or covered in insulated keg jackets depending on the system.

Draught beer goes great with outdoor events, but the temporary setting prohibits use of traditional direct-draw or long-draw draught equipment. We will look at the most common systems, starting with the simplest.

Picnic Pumps or Party Taps

The simplest type of party system is the picnic pumps. They are available from several manufacturers in various styles. The newest models are very small units with built-in hand pumps. Picnic pumps or party taps allow draught beer dispense for a one-day occasion, party or event. These systems do, however, compromise accepted standards (i.e., they introduce air as the compressed gas to pressurize the keg) of draught dispense in order to offer a simple method for serving draught beer. In the simplest systems, the beer flows from the tap up the beer line and out through a simple plastic faucet. Gas pressure comes from compressed air introduced by way of a hand-operated pump integrated into the coupler.

The key features to look for in picnic pumps are:

- Pressure release vents (A) to reduce foaming
- A metal fitting (B) for connecting to the keg.

The metal party pumps are more durable than plastic party pumps.

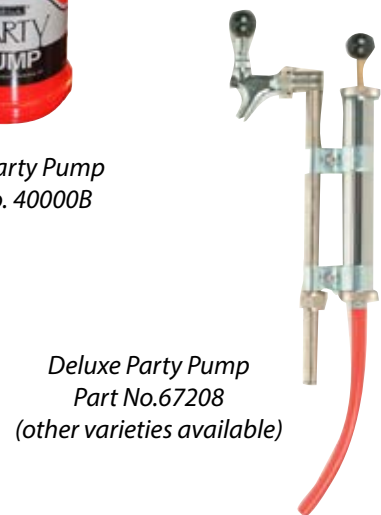

Tapping the Keg with a Picnic Pump or Party Tap

- 1) Insert locking lugs at bottom of the tap into the locking slots of the keg tapping well.
- 2) Turn the tap one-quarter turn clockwise to affix tap to the keg.
- 3) Tap the keg by pulling the tap handle up out and down.
- 4) Hold the beer container in one hand and the tap faucet in the other.
- 5) Push down on the tap faucet to allow the beer to flow into the beer container. There will be a little foam initially.

Pumping the Keg

Do not pump the keg until the beer flow is very slow and begins to foam!

When needed, just push the pump a few times to speed up the flow of beer. Continue to do this for the complete keg. DO NOT OVER-PUMP.

Note: Do not pump air until beer has been drawn. The keg should never be lifted using the pump as a handle. Doing this will damage the keg and the pump. Lifting bends the lugs of the kegs and causes a poor fit for tavern heads. This loose fit causes foaming.

Since these systems introduce compressed air into the keg, they are only suitable for situations where the beer will be consumed in a single day. Also, these dispensing systems typically do not produce the best serving results, since systems balancing and correct applied pressure is not consistent.

For best results, the keg must be kept in ice and consistently — but not excessively — pumped as the contents are dispensed.



Party Packs

Party packs are available that have both the picnic/party pump and a large bucket in which to place the keg and ice. In these tubs the keg and the beer line should be submerged in the ice. The beer line attaches to a short shank and a standard faucet is used to dispense the beer.

Jockey Boxes

Jockey boxes offer another way to improve on the picnic tap and party pack as a solution for portable dispense. Here CO₂ is used to pressurize the system. There are a couple of methods used in jockey boxes: cold plate jockey box and coil jockey jockey box.

1) Cold Plate Jockey Box

A cold plate equipped jockey box uses ice to cool beer flowing through the cold plate. A cold plate cooler is an insulated box, like a picnic cooler, with an aluminum or stainless steel plate inside it. Inside the plate is a series of stainless steel lines through which beer flows and is cooled by the surrounding ice. The cold plate is appropriate for beer dispensed at a moderate rate. It is recommended that kegs used with a cold plate be iced.

Follow this procedure to operate a cold plate

1. Connect the cooler to the keg with a beer line jumper. Run a little beer through the cold plate, prior to putting on the ice, to prevent any water in the lines from freezing once the unit is in operation.
2. Place ice both underneath and on top of the cold plate in the ice chest. As time passes, the ice should be knocked down onto the plate as it melts. Ice should be added periodically and water drained from the ice chest
3. Fill the cooler with ice cubes— not block ice or shaved ice.
4. Place a bucket under the drain to catch the water from the melting ice.
5. Open the drain at the bottom of the cooler to drain out the water as the ice melts.
6. Open the faucet and check the beer flow. If it is foamy and slow, increase the CO₂ pressure until the proper flow is reached. This will usually be between 25 to 30 lbs. of pressure.
7. Check the ice and periodically knock it down onto the cold plate to make sure it stays in contact with cold plate.

2) Stainless Steel Coil Jockey Box

A coil jockey box works much in the same way as the cold plate. You can make a coil box out of any type of commercial cooler/box. Use a 50-ft. coil of uninsulated polyurethane or stainless steel tubing to route the beer through the coil which is cooled by ice cubes and water which covers the coil. Many commercial types are available.

Coil jockey boxes pour beer at a faster rate than those equipped with a cold plate for they have less systems resistance in the stainless steel line. Thus, they better suit situations where you need higher volumes or faster pours. Coil jockey boxes can pour beer efficiently even with the kegs at temperatures slightly above 50°F however, it is recommended that the kegs be iced down to make sure the system runs efficiently.

Coil Box Procedure

Follow this procedure to operate a coil box:

1. Connect the cooler to the keg with a beer line jumper.
2. Prior to filling the cooler with ice and water, run a small amount of beer through the coil box to prevent any water in the lines from freezing once the unit is in operation.
3. Fill the cooler with ice cubes— not block ice or shaved ice.
 - a. Then add a small amount of water.
 - b. This insures that all surface area of the coils are in contact with the iced water, eliminating hot spots.
 - c. Keep the drain closed. The combination of ice and water chills the beer.
4. Set pressure at 35 to 40-lbs. for stainless steel coils (120 ft.), 30 lbs. for homemade poly coil (50 ft.).

Note: A beer “Y” can be used to hook up one keg to two faucets on a cold plate or coil system.



The kegs feeding this type of system should be placed into a horse trough or large plastic bucket similar to the party pack bucket and kept iced down. These systems are not appropriate for day-to-day use, as draught beer is perishable. Partial kegs remaining from temporary service are not usable in other settings.

Cleaning and Maintenance

Jockey boxes must be cleaned after each use to prevent mold growth between events. Review the Sanitation section of this manual for the fine points on cleaning the couplers, lines and faucets.

Note:

- 1) If the recirculation pump is capable of being run dry:
 - a) Before breaking down recirculation loop, remove inlet from rinse water with pump running so air pushes out all of the rinse water in the lines.
- 2) If the recirculation pump is not capable of being run dry:
 - a) After breaking down the re-circulation loop and reattaching faucets, tap an empty cleaning canister and use the gas pressure to blow all of the water out of the lines.

Planning a Party

The following factors should be considered when planning for a picnic or party.

How many people will be attending?

What type of people are they? (College age or senior citizens, heavy beer drinkers, etc.)

Will liquor be served?

Will the beer be free or will there be a charge?

Are there any licenses or special permits required?

What time will the function begin and end?

Will there be adequate refrigeration?

What size and number of cups will be required?

Is there a need for restrooms?

How will the garbage be collected?

Will there be a responsible drinking program in place?

Will there be non-alcohol beverages available?

OTHERS:

Although it is normally not your responsibility to accomplish these tasks yourself, it's a good idea to review them with the person or persons who are responsible for setting up the event. A successful function will enhance your distributorship's image and lead to increased sales.

When planning a picnic or party how much ice is needed?

To cool cans or bottles of beer and/or soda, 8-10 lbs. of ice per case is needed.

- This should adequately keep beer/soda cool for approximately 4-6 hours.
- When using ice to cool cans and bottles, place the cans or bottles in the bottom of the holding tank or cooler and spread the ice on top. Add a small amount of water so that the water will become cold and better distribute the cooling effects of the ice.

When keg beer is being served, figure 40-50 lbs. of ice per half-barrel.

- This will keep the beer cool for 4-6 hours.
- When icing keg used in conjunction with cold plates or coil boxes kegs, figure 20-40 lbs. of ice per half-barrel.
- Cold plates should be full of ice at all times. Coil boxes should be filled with ice and water.

Check the weather forecast for last minute weather changes. You may wish to increase the amount of ice if you are expecting high temperatures or high humidity.





Section 10

Troubleshooting



10



Draught Beer Systems Troubleshooting

The key to effective and efficient troubleshooting is to use a systematic approach that focuses on the most common problems. This will help you:

- Identify those problems that occur most frequently before exploring those problems that are less common
- Project a more professional approach to solving a problem
- Save valuable time in locating a problem
- Reduce the chance that an uncommon problem will be overlooked

Tools

The first step in troubleshooting is to bring the tools necessary to do the job as described in each of the previous sections.

Troubleshooting Process

In order to find the true cause of the problem in the shortest amount of time, we recommend that you follow this process on every call.

- Ask the retailer to describe the problem.
- Find out which brands are affected, when the problem started, does it reoccur and if there is a pattern.
- **CHECK THE TEMPERATURE** of the beer in the cooler and at the faucet; 34 to 38°F is ideal. Any temperature above 40° F may cause foaming problems.
- **CHECK THE PRESSURE.** Make sure that the applied gauge pressure is set properly for this account. Refer to the Systems Balancing section of this manual.
- **CHECK THE SANITATION** procedures. Make sure that the system and glasses are being cleaned properly. Refer to the Sanitation section of this manual.
- **CHECK THE COUPLER AND KEG.** Make sure that the keg valve and coupler are in good condition and have all the appropriate seals. Refer to the Basic of Building a Draught Beer System section of this manual.
- **CHECK THE FAUCET.** Make sure the faucet is clean and is properly assembled with all the appropriate parts. Refer to the Basic of Building a Draught Beer System section of this manual.
- **CHECK THE POWER PAK.** If the account is using a refrigerated line system, check to see that it is operating properly. Refer to the Refrigerated Line Troubleshooting page later in this section.

Wild Beer

Description

Beer is all foam or too much foam and not enough liquid beer.

Causes

Beer drawn improperly
Creeping regulator
Applied pressure is set too high
Hot spots in line
Use of non-insulated beer line
Beer runs are too long for proper cooling
Tapped into a warm keg
Cooler malfunctioning
Kinks, dents, twists, or other obstructions in line
Faucets in bad, dirty or worn condition

Unpalatable Beer

Description

Off-Taste

Causes

Dirty or old beer lines
Dirty faucet
Contaminated or unfiltered air source
Unsanitary bar conditions

Cloudy Beer

Description

Beer in glass appears hazy, not clear.

Causes

Frozen or nearly frozen beer
Old beer
Beer that has been unrefrigerated for long periods of time
Dirty glass
Dirty faucet
Unrefrigerated foods placed on top of cold keg
Contaminated air source

False Head

Description

Large soap-like bubbles, head dissolves very quickly.

Causes

Applied pressure required does not correspond to beer temperature
Small beer line into a large faucet shank
Beer lines warmer than beer in keg
Dirty glasses
Improper pouring technique



Flat Beer

Description

Foamy head disappears quickly. Beer lacks usual zestful brewery fresh flavor.

Causes

- Dirty glass (not beer clean)
- Sluggish regulator
- Applied pressure is set too low
- CO₂ is turned off at night
- Contaminated air source (associated with compressed air)
- Moisture in air system
- Beer too cold
- Loose tap or vent connections

How to Troubleshoot a Refrigerated System

Step 1

Check with the owner to see if he has retained the applied pressure tag shipped with glycol system. If so, check and just to indicated pressure. Don't try to estimate what the pressure should be! All glycol systems have a "designed" pressure that must be used.

Step Two

Take the top off the power pak and determine if the circulating pump is running. If not, check to see if the plug-in cord was inadvertently unplugged. If the plug is still in the back, check and see if the fuse controlling the circuit is blown.

Step Three

If the pump is running, be sure the glycol is at the proper level. Reach down into the refrigeration bath and lift up the return line from the refrigerated housing. If no liquid is flowing through this line, the pump may have lost its prime. Re-prime by injecting water from a hose, up the return line, until it flows back through the pump. Prime should then be reestablished and a continuing stream of circulated water and glycol mixture should come out of the return line.

Step Four

What is the temperature of the coolant? The coolant temperature should be between 23° and 34°F. If it is warmer set the thermostat to a colder position.

Step Five

What is the temperature of the walk-in cooler? Not the air temperature, but the liquid temperature. Put a few ounces of water in an enclosed container such as a jar with a lid. Place the enclosed container of water in the walk-in cooler; allowing two hours for the water temperature to stabilize. Use your dial pocket thermometer to check the temperature of the water. It should be between 35 and 40° F.

Step Six

Consider this series of questions:

- A. Is the beer breakup only occasional? If so, is the walk-in cooler used other than for beer? Is the door left open for long periods of time? Is warm beer stacked in cases periodically in the cooler? If the answer to these questions is yes, these may well be the causes of your problems.
- B. Is the beer tapped in a series? If so, is the new keg always added to series ahead of a partial keg in the line? If it is added behind a partial keg it can cause beer breakdown.
- C. Is the tapping equipment in use that which was shipped from the factory? Often the substitution of alien equipment can cause a problem.
- D. Is the walk-in cooler too cold? If the beer temperature is under 35°F in the walk-in cooler, the beer can over-carbonate if the applied gauge pressure is not set properly; particularly if the beer volume of the account is moderate. These questions can be considered an adequate checklist, which should provide 99% of the answers required to correct an unsatisfactory beer draw.



Notes





Section 11

Sanitation



11



Sanitation

In addition to alcohol and carbon dioxide, finished beer contains proteins, carbohydrates and hundreds of other organic compounds. Yeast and bacteria routinely enter draught systems where they feed on beer and attach to draught lines. Minerals also precipitate from beer leaving deposits in lines and fixtures.

Within weeks of installing a brand-new draught system, deposits begin to build up on the beer contact surfaces. Without proper cleaning, these deposits soon affect beer flavor and undermine the system's ability to pour quality beer. When using proper solutions and procedures, line cleaning prevents the buildup of organic material and mineral deposits while eliminating flavor changing microbes. Thus, a well-designed and diligently executed maintenance plan ensures trouble-free draught system operation and fresh, flavorful beer.

Cleaning Standards

Many states require regular draught line cleaning, but all too often the methods used fall short of what is needed to actually maintain draught quality. Please note that all parts of the recommendations/guidelines below will give you effective systems line cleaning.

The proper cleaning solution strength won't be effective if the temperature is too cool or there's insufficient contact time with the lines. The lines themselves will remain vulnerable to rapid decline if faucets and couplers aren't hand-cleaned following the recommended procedures.

The distributor and retailer, though they may or may not clean their own draught lines, have a vested interest in making sure the cleaning is done properly. Clean lines make for quality draught beer that looks good, tastes great and pours without waste. The guidelines below will help you monitor your draught cleaners — no matter who they are — to ensure that your system receives the service it needs to serve you and your customers well.

Cleaning Safety

Line cleaning involves working with hazardous chemicals. The following precautions should be taken:

- Cleaning personnel should be well-trained in handling hazardous chemicals.
- Personal protection equipment including rubber gloves and eye protection should be used whenever handling line cleaning chemicals.
- Cleaning solution suppliers offer Material Safety Data Sheets (MSDS) on their products. Cleaning personnel should have these sheets and follow their procedures while handling line cleaning chemicals.
- When diluting chemical concentrate, **always add chemical to water and never add water to the chemical.**
 - a) Adding water to a concentrated caustic chemical can cause a rapid increase in temperature, possibly leading to violent and dangerous spattering or eruption of the chemical.

System Design and Cleanliness

Draught system designs should always strive for the shortest possible draw length, using the smallest ID, to help reduce operating challenges, drawing problems and line cleaning costs. Foaming beer and other pouring problems waste beer in greater volumes of beer as the draw length and ID increases. Line cleaning wastes beer equal to the volume of the beer lines themselves. Longer runs also place greater burdens on mechanical components, increasing repair and replacement costs.

Large venues like stadiums, arenas and casinos often combine very long draught runs with long periods of system inactivity that further complicate cleaning and maintenance. Additional maintenance costs eventually outweigh any perceived benefits of a longer system.

Other Line Cleaning Methods

Devices that purport to electrically or sonically clean draught lines are not a suitable substitute for chemical line cleaning. Although some sonic cleaners may inhibit bacteria and yeast growth, they have little or no cleaning effect on draught hardware and fittings.



System Maintenance: Line Replacement

- All vinyl jumpers and vinyl direct draw lines should be replaced every 3 years.
- All long-draw trunk line should be replaced in the following instances:
 - a) When the system is 10 years or older.
 - b) When flavor changes are imparted in a beer's draught line from an adjacent draught line.
 - c) When any line chronically induces flavor changes in beer.
- **Draught lines may need to be replaced after pouring root beer, fruit-flavored beers, margaritas or ciders.** Such beverages may permanently contaminate a draught line and possibly adjacent draught lines in the same bundle. Such contamination precludes future use of that draught line for beer.
- In the case where a coupler's gas back flow valve (Thomas valve) is or ever has been missing, the gas line may well have been compromised and should be replaced.

Detailed Recommendations

The following sections detail the recommendations on draught line cleaning. We begin with the basic issue of tasks and their frequency, then move into the more involved questions of cleaning solutions and procedures.

Cleaning Frequency and Tasks

Every two weeks (14 days)

- Draught lines, straight lines or split lines (lines that are "teed") should be cleaned with a caustic line cleaning chemical following the procedures outlined in this chapter. All faucets should be completely disassembled (*Fig. 11.1*) and cleaned.
- All keg couplers or tapping devices should be scrubbed clean.

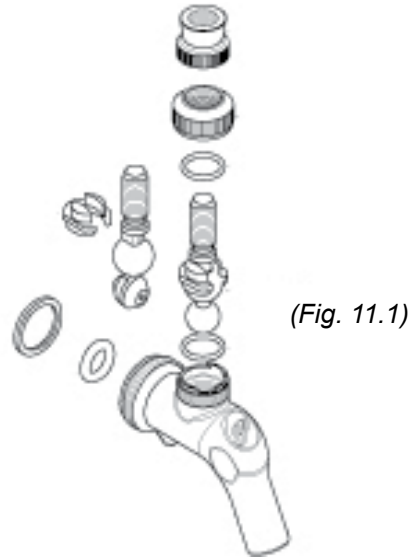

These guidelines reflect the key actions needed to maintain draught systems and pour trouble-free high-quality beer. Before performing these actions, please read the detailed recommendations found elsewhere in this chapter as they contain many details important to effective and successful cleaning.

- Push beer from lines with cold water.
- Clean lines with caustic solution at manufacturers recommended level. Maintain a solution temperature of 80° to 125°F.
- Caustic solution should be circulated through the lines for 15 minutes at a velocity up to 2 gpm for electric pump cleaning or left to stand in the lines for no less than 20 minutes for static cleaning.
- Disassemble and hand clean faucets; hand clean couplers.
- After cleaning, flush lines with cold water until pH matches that of tap water and no visible debris is being carried from the lines.

Quarterly (every three months)

- Draught lines should be destoned quarterly with an acid line cleaning chemical or a strong chelator in addition to the regular caustic cleaning.
- All FOB-stop devices (a.k.a. beer savers, foam detectors) should be completely disassembled and hand detailed (cleaned).
- All couplers should be completely disassembled (*Fig. 11.2*) and detailed.

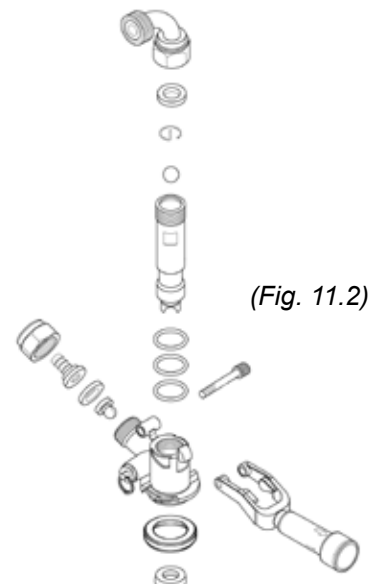

Perform acid cleaning of draught lines as follows:

- Push beer or caustic cleaner from lines with cold water.
- Clean lines with an acid line cleaner mixed to manufacturer's guidelines. Maintain a solution temperature of 80° to 125°F.
- Circulate the acid solution through the lines for 15 minutes at a velocity up to 2 gpm for electric pump cleaning or let stand in the lines for no less than 20 minutes for static cleaning.
- After acid cleaning, flush lines with cold water until pH matches that of tap water and no visible debris is being carried from the lines.

Cleaning Solutions and Their Usage

Caustic-based Cleaning Chemistry (*Beer Line Cleaner*)

- Caustic chemicals remove organic material from the interior of the draught line, hardware and fittings. The removal of this buildup prevents growth of beer-spoiling bacteria such as lactobacillus, pediococcus and pectinatus.
- Use a caustic cleaner specifically designed for draught line cleaning that uses either sodium hydroxide, potassium hydroxide or a combination of both.
- Some caustic line cleaning solutions add EDTA or another chelating agent to help remove calcium oxalate (beer stone) from draught lines.
- Never use solutions that contain any amount of chlorine for line cleaning.
- Based on brewery testing, we recommend that caustic line cleaning solution be mixed to a solution strength at manufacturers recommended level.
- Mix caustic solution with water warmed to a temperature between 80° to 125°F.
- Caustic cleaner must remain in contact with the draught line for at least:
 - a) 15 minutes when solution is being recirculated, and
 - b) 20 minutes for static, or pressure pot cleaning.



*Beer Line Cleaner
Part No. BLC*

Acid Chemical (*Acid Line Cleaner*)

- Acid line cleaner removes inorganic materials such as calcium oxalate (beer stone) and calcium carbonate (water stone) from the interior of the draught line, hardware and fittings.
- EDTA or another chelating agent added to the regular caustic cleaning solution may reduce calcium oxalate buildup in draught lines and may decrease the need to clean regularly with an acid based cleaner.
- Acid-based line cleaners suitable for draught line cleaning contain solutions of phosphoric acid.
- Some acid-based cleaners use acids that can harm your draught equipment:
 - a) Hydrochloric acid corrodes to stainless steel and should not be used for cleaning draught lines.
 - b) Nitric acid is not compatible with nylon products, including some commonly used draught line tubing, and should not be used for cleaning draught lines.
- Mix acid line cleaner to the solution strength recommended by the manufacturer.
- Mix acid line cleaner with water warmed to a temperature between 80° to 125°F.
- Acid solution must remain in contact with the draught line for at least:
 - a) 15 minutes when solution is being re-circulated, or
 - b) 20 minutes for static, or pressure pot cleaning.



*Acid Line Cleaner
Part No. ALC*

Water/Rinsing

- Always flush draught lines with fresh water before pumping chemical into the line.
- Always flush draught lines with water after using any chemical solution (caustic and acid).
- Continue water flushing until:
 - a) No solid matter appears in the rinse water.
 - b) No chemical residue remains in the draught line.



- Confirm chemical removal by testing the solution with pH strips or a pH meter.
 - a) Before beginning the rinse, draw a reference sample of tap water and test its pH.
 - b) During rinsing, test the rinse water exiting the draught system periodically.
 - c) When the pH of the rinse water matches that of the tap water, the chemical is fully flushed out.
- Chemical solution must never be flushed from draught lines with beer.

Cleaning Methods and Procedures

To be effective, cleaning solutions need to reach every inch of beer line and every nook and cranny of the connectors and hardware. You can hand clean some items like couplers and faucets, but most of the system must be reached by fluid flowing through the beer lines.

The industry currently uses two cleaning procedures for beer lines:

1. Recirculation by electric pump *external pump or submersible* (Fig. 11.3)
2. Static pressure cleaning pot (Fig. 11.4)



(Fig. 11.3)



(Fig. 11.4)

Recirculation by Electric Pump

Electric pump re-circulation improves cleaning efficiency by constantly moving the cleaning solution through the beer lines through the cleaning period. You can use this method on all draught systems, and it is the preferred approach for nearly all long-draw systems.

Key considerations in setting up an electric pump cleaning:

- The chemical flow should be the reverse of the beer flow wherever possible.
- Configure cleaning loops to achieve a flow rate up to 2 gpm, or approximately twice the flow rate for beer.
 1. The flow rate can be controlled by:
 - a) Minimizing the number of draught lines cleaned at one time.
 - b) Increasing the size of the pump used.
 2. Assess the flow rate by filling a standard 60 oz. beer pitcher with the cleaning solution outlet. At 2 gpm it fills in 15 seconds or less.
- The pressure on the draught lines during recirculation should never exceed 60 psi.
- Under these conditions, chemical solution should recirculate for a minimum of 15 minutes. Static or pressure pot cleaning offers an alternative method to clean runs of less than 15 ft. This requires 20 minutes of contact time with the cleaning solutions to make up for the lack of circulation. The remainder of this chapter covers use of these cleaning methods, starting with setup and proceeding to the detailed steps for each procedure.

Before You Start

- Regardless of your cleaning methods, some system designs require specific attention before you begin cleaning. Here's a list of items to check and consider.
- On glycol-chilled systems, the glycol chiller should be shut off where possible to maintain solution temperature during cleaning. Failure to do so compromises cleaning effectiveness and may cause cleaning solution or rinse water to freeze in the lines.
- In pneumatic beer pump systems:
 - a) Turn off the gas supply to the pumps.
 - b) On the line(s) to be back flushed, set the pump valve orientation to "Back flush." Pumps that lack a "back flush" option may be damaged by cleaning and should be cleaned using a different method.
- All legs in "split lines" (lines that are "teed" in the cooler or under the bar to feed more than one faucet from a single keg) must be cleaned as completely separate draught lines.



Recirculation– Step-By-Step Electric Pump Cleaning

Procedure:

- 1) Begin by connecting two keg couplers with a cleaning coupler. (Do not engage the couplers.)
 - a) If cleaning four lines, connect a second set of lines with another cleaning coupler, creating a second “Loop”
Cleaning more than four lines at once is not recommended, as it will be difficult to achieve the proper chemical flow rate.
 - b) To clean the lines and couplers used for series kegs, connect the couplers attached to the gas lines and place series caps with check ball lifters on all other couplers.
- 2) On the corresponding lines at the bar, remove both faucets from their shanks.
 - a) When cleaning two lines, attach the “Out” hose from the pump to one shank and a drain hose or spare faucet to the other shank.
 - b) When cleaning four lines, attach the “Out” hose from the pump to one shank, connect the other shank in the loop to a shank in the second loop with a ‘jumper’ hose and attach a drain hose or spare faucet to the remaining shank in the second loop.
 - c) When cleaning four lines, ensure that the drain hose and “Out” hose from the pump are not on the same coupler “loop.”
- 3) Fill a bucket (“Water Bucket”) with warm water and place the “In” hose into the water.
 - a) Turn pump on and flush beer into a second bucket (“Chemical Bucket”) until the line runs clear with water.
 - b) Shut pump off and discard the flushed beer.
- 4) Turn pump back on allowing warm water to run into the clean Chemical Bucket.
 - a) Measure the flow rate of the liquid by filling a beer pitcher or some container with a known volume. Flow rate should be a minimum of up to 2 gpm (256 oz.)
 - aa) If cleaning is configured for four lines and flow rate is too slow, remove the jumpers and clean each pair of lines separately
 - b) Allow bucket to fill with just enough water to cover the inlet hose of the pump.
 - c) Add the appropriate amount of line cleaning chemical based on manufacturers recommended level.
- 5) Remove the ‘In’ hose from the Water Bucket and place into the Chemical Bucket.
 - a) There should now be a closed loop
 - b) Water should be draining into the same bucket that the pump is pulling from.
- 6) Allow solution to recirculate for a minimum of 15 minutes.
 - a) While waiting, clean your faucets.
 - b) Fill Water Bucket with cold water.
- 7) Begin your rinse by removing the “In” hose from the Chemical Bucket and placing it into the Water Bucket (filled with cold water).
- 8) Continue pumping cold water from the Water Bucket into the Chemical Bucket (shutting off pump and dumping Chemical Bucket as needed) until all chemical has been pushed out of the draught lines and there is no solid matter in the rinse water.
- 9) Finish up by shutting off the pump, detaching the cleaning coupler, and replacing the faucets.

When Finished

Be sure to return all system components to their original functional settings; i.e., turn glycol pumps back on, turn on gas supply to pneumatic beer pumps, etc.



Static- Step-By-Step Pres



(Fig. 11.5)

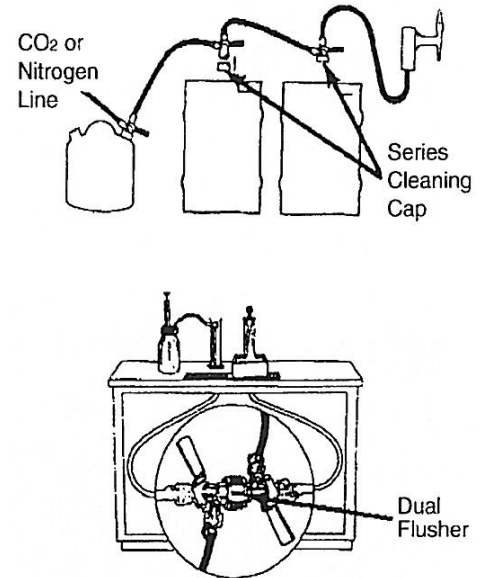
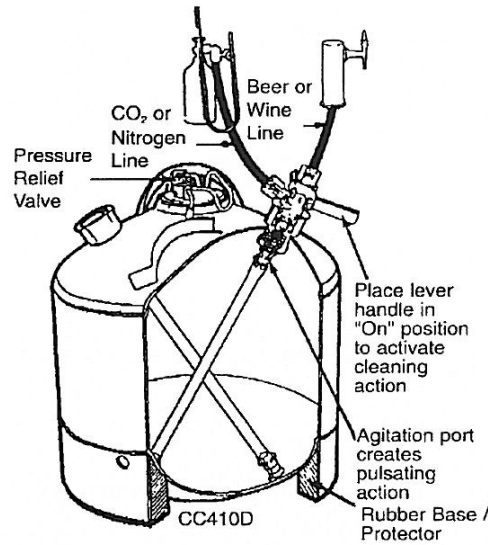

- 1) Fill the cleaning canister (Fig. 11.5) with clean water.
- 2) Untap the keg and tap the cleaning canister. Engage the tapping device.
 - a) When cleaning series kegs, connect the tapping devices attached to the gas lines and place series caps on all other tapping devices.
- 3) Open faucet until the beer is flushed out and clear water is pouring.
- 4) Untap the canister and fill the canister with cleaning chemical mixed to the appropriate strength.
- 5) Tap the canister again.
- 6) Open the faucet until the water is flushed out and chemical solution is pouring from the faucet.
- 7) Shut off the faucet and untap the canister.
 - a) If the system is driven with pneumatic beer pumps, shut off the gas supply to the pumps to turn them off.
- 8) Remove the faucet and clean.
- 9) Replace faucet and retap the canister.
- 10) Pull through solution again to replenish the contents of the draught line. Chemical should be replenished at least twice during the cleaning process.
- 11) Allow to soak for a total of 20 minutes.
- 12) Untap canister, empty and rinse.
- 13) Fill the canister with clean, cold water and retap.
- 14) Open the faucet and rinse until all chemical has been flushed out and there is no solid matter in the rinse water.
- 15) Finish by untapping the canister, retapping the keg and pouring beer until it dispenses clear.

When Finished

Be sure to return all system components to their original functional settings; i.e., turn back on glycol pumps, turn on gas supply to pneumatic beer pumps, etc.



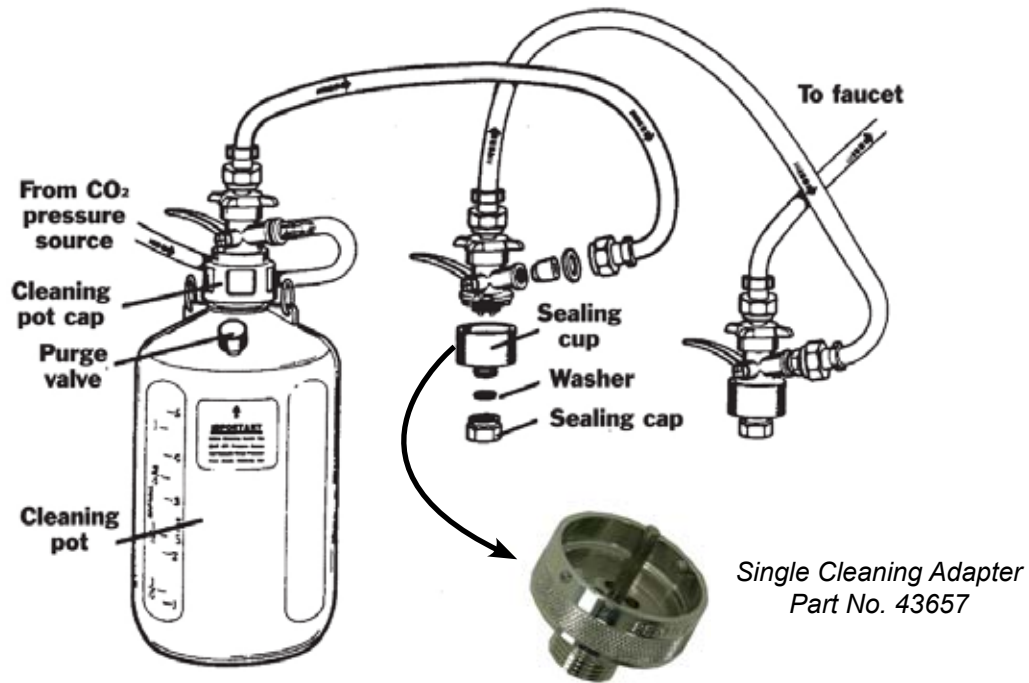

Cleaning Systems with Series Systems

The system hook-up for series systems is the same as for a single keg with one exception.

1. Remove all couplers from kegs.
 - a) Attach the coupler closest to the CO₂ to the cleaning adaptor.
 - b) Attach series sealing cleaning cups to all the other couplers (use washer in sealing cap).
 - c) Place the couplers in the tapped-in position starting with the coupler nearest to the faucet and working back (normal applied pressure should always be used when cleaning lines.)
2. Now follow normal cleaning process.
3. When the lines are cleaned and flushed. Remove series sealing cleaning cups and let the rinse water in the jumper lines drain into a waste bucket.
4. Retap kegs.

Recommended Sanitation Cleaning Kit

It is recommended that each Line Cleaning Technician be equipped with the following core items.

Cleaning Pumps

1. Electric Cleaning Pump for Beer Lines of 5 – 50+ ft. and/or
2. Submersible Electric Cleaning Pump for beer lines less than 25 ft.

Cleaning Pot(s) for beer lines less than 25 feet

3. Single tank and/or
4. Double tank
5. Cleaning agent
6. Cleaning agent

Cleaning Brushes

7. Faucet Coupling Brush– for cleaning faucet and coupler probes
8. Faucet Coupling Brush– for electric drills
9. 3/16" Shank & Bent Tube Brush/Tube Elbow/Shank Brush– for cleaning same



10. Abrasive Pad– to clean parts
11. Double Male Adaptor– to connect two beer lines together
12. Cleaning Adaptor– used to attach pump “out flow” to faucet coupler
13. Cleaning Nozzle– replaced faucet while it is being cleaned
14. Double Male Adaptor– use to connect two non series taps
15. Series Cleaning Cup– place on bottom of all couplers in series except the gas coupler

Tools

16. Bladed screwdriver– to disassemble parts
17. Spanner Wrench– to remove faucet
18. Channel Locks– to disassemble tap knob and faucet
19. Crescent Wrench– to disassemble coupler’s CO₂ outlet
20. CO₂ Pressure Check Gauge– check systems pressures
21. Dial Thermometer– to take temperature of the beer
22. Pipe Cleaners– to clean vent holes in faucets
23. Single Valve Test Coupler– check systems pressures and temperatures
24. Mechanics Combination Wrench– disassemble couplers (quantity of 2 recommended)
25. 3-5-gal. buckets for cleaning and rinsing

Beer Line Replacement Guidelines

It is recommended that the beer lines in every system (if possible) be periodically replaced, as over time they can yellow, change in restriction and crack. As a general guideline we recommend the following time lines for beer line replacement.

- All vinyl jumpers and vinyl direct draw lines should be replaced every two years.
- All polyethylene and Barrier trunk lines (if possible) should be replaced in the following instances:
 - a) When the system is ten years old or older.
 - b) When flavor changes are imparted in a beer’s draught line from an adjacent draught line.
 - c) When a soiled line is chronically producing flavor changes in the beer.



Notes





Section 12

Serving Draught Beer



12



Serving Draught Beer

To serve a “Perfect” Glass of draught beer you must have the following:

A consumer’s experience can be ruined by improper pouring, glass residue and unsanitary practices. In this chapter, we review the factors required to deliver high-quality draught beer to the consumer. To achieve the qualities the brewer intended, beer must be served following specific conditions and techniques. Let’s review some of the critical conditions necessary for proper draught dispense as follows:

A Draught Beer System that is Properly Designed and Maintained

When set up properly your draught system pours perfect draught beer from its faucets. The following conditions, as we have seen, will allow you to have a system that is properly set up:

- a) The beer should be served between 38° and 42°F. To accomplish this,
 - The temperature of the beer in the cooler should be between 32° and 38°F
 - The temperature of the air blowing through a forced air system should be at most 38°F.
 - The glycol cooling the beer lines in a long-draw system should be set to 27° to 32°F.
- b) The system must be balanced (Applied Gauge Pressure = Systems Resistance)
 - Normal flow rate of 2 oz. per second for high volume accounts
 - May be less for other accounts to meet the retailer’s specific needs.



Beer Clean Glassware

A perfectly poured beer requires a properly cleaned glass. As a starting point, glassware must be free of visible soil, chips and marks. A beer clean glass is also free of foam-killing residues, such as lipstick, lip balm, food and body oils, and lingering aromatics such as sanitizer, hand lotions and perfumes. To accomplish this, the glasses must not only be hygienically clean, but must be beer clean. We recommend that a freshly beer cleaned glass be used every pour.

Sink Setup:

Most accounts have three-sink tanks for manually washing beer glassware. Many health departments are now requiring a four-tank set up on new account installations. In both cases do the following to acquire a beer clean glass using :

- a) First clean up any chemicals, oils or grease from other cleaning activities
- b) Next, clean the three/four sinks and work area using a non oil-based beer compatible sink cleanser. (Detergents and sanitizers suitable for beer glass cleaning are available through restaurant and bar suppliers.
- c) Set up your tanks as follows to prepare for washing the glasses. Tanks may be set up from left to right or right to left depending on the retailer’s layout.

Three-tank Sinks (Fig. 12.1)

Tank 1 – Wash Tank (A)

This tank is used to wash the glasses

1. This tank should be fitted with a dump funnel (Fig. 12.2) in which to pour the residue from the glass prior to its being washed.
2. Glasses should NOT be emptied into the cleaning water as it will dilute the cleaning solutions.
3. Your cleaning brushes should be placed in this tank. You should have at least two sets of these brushes and they should be cleaned and changed with each shift or approximately every eight hours.
4. Insert your drain tube in the sink drain and in turn insert the cleaned dump funnel in the top of the drain tube.
5. Begin to fill up this tank with water that is as hot as bath water.
6. While water is filling the tank, pour the glass washing agent directly on the center brush and not in the water. Fill tank to the top of the drain tube.

(Fig. 12.1)



(A) (B) (C)



(Fig. 12.2)



Tank 2 – Rinse Tanks (B)

This tank is used to rinse the cleaning agent off of the glass.

1. Insert drain tube and fill this tank with luke-warm water.
2. When washing the glassware leave the water faucet running slowly over this tank. This will allow the suds and cleaning agents that float to the top of the tank to go down the drain.

Tank 3 – Sanitizing Tank (C)

This tank is used to sanitize the glassware.

1. Insert drain tube and fill this tank with minimum 90 ° F water.
2. Mix in non-oil-based sanitizing solution or powder.
3. Sanitizers typically contain chlorine and have test strips available so you can check the pH and chlorine content of the sanitizing tank. Chlorine concentration should be 100 ppm or at the required local health department concentration.

Four-tank Sinks

Tank 1 – Dump Tank

This tank is used to pour the residue from the glass prior to its being washed.

1. Glasses should NOT be emptied into the cleaning water as it will dilute the cleaning solutions.

Tank 2 – Wash Tank

This tank is used to wash the glasses.

1. Your cleaning brushes should be placed in this tank. You should have at least two sets of these brushes and they should be cleaned and changed with each shift or approximately every eight hours.
2. Insert your drain tube in the sink drain and begin to fill up this tank with water that is as hot as bath water.
3. While water is filling the tank, pour the glass washing agent directly on the center brush and not in the water. Fill tank to the top of the drain tube.

Tank 3 – Rinse Tanks

This tank is used to rinse the cleaning agent off of the glass.

1. Insert drain tube and fill this tank with luke-warm water.
2. When washing the glassware leave the water faucet running slowly in this tank. This will allow the suds and cleaning agents that float to the top of the tank to go down the drain.

Tank 4 – Sanitizing Tank

This tank is used to sanitize the glassware.

1. Insert drain tube and fill this tank with water temperature that should be at a maximum 90°F.
2. Mix in non-oil-based sanitizing solution or powder. Sanitizers typically contain chlorine and have test strips available so you can check the pH and chlorine content of the sanitizing tank. Chlorine concentration should be 100 ppm or at the required local health department concentration.



Manually Cleaning the Glassware Using Hand or Electric Brushes

1. Dump the residue from the glass into the dump funnel or dump tank:

2. Wash the glass

- a) To wash glass manually, put it over the center brush in wash tank and rotate clockwise then counterclockwise 180° a number of times. The only grease that is good for glassware is “elbow grease.” Be sure to clean the bottom of the glass.
- b) To wash glass using electric brushes, put it over the center brush in the wash tank and turn on the electric brushes. This will clean both the inside and outside of the glass at the same time. Be sure to clean the bottom of the glass (Fig. 12.3).
- c) To rinse the glass, place bottom/butt of the glass down into the rinse water tank. This allows the water to completely rinse the inside and outside of the glass at the same time. If time permits, a double dunk is recommended and preferred.
- d) To sanitize the glass, place bottom/butt of the glass down into the sanitizer tank solution (Fig. 12.4).

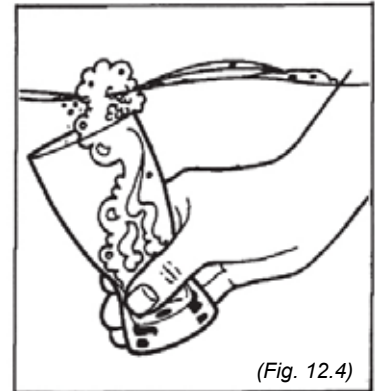
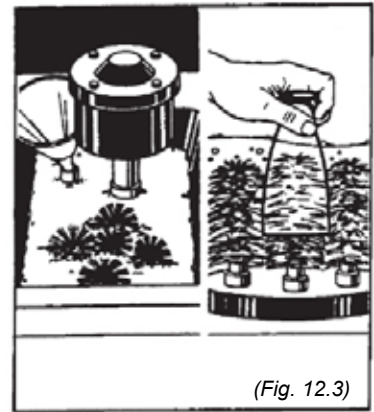

Automatic Glass Washing Machines (Fig. 12.5)

Dedicate this machine to cleaning bar and beer glassware only. Do not subject it to food or dairy because of the excessive grease and oils in food.

- 1) Use correct detergent, sanitizer and rinse agents in properly metered amounts; all non-oil based.
- 2) Check concentrations once each day using kits or follow detergent and sanitizer supplier recommendations.
- 3) Use water temperatures of 130° to 140°F. High temperature machines designed to operate at 180°F can be used without additional chemical sanitizers. Please check your health department for local requirements.
- 4) Maintain the machine to assure good water flow through the system including free flow through each nozzle and washer arm.
- 5) Regularly service the machine based on the manufacturer's or installer's guidelines.

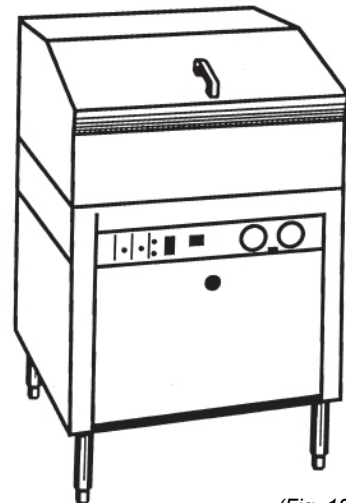

Testing for “Beer Clean” Glass

Beer poured into a beer clean glass forms a proper head and creates residual lacing as the beer is consumed. After cleaning, you can test your glasses for beer clean status using four different techniques:

- Sheeting Test
- The Salt Test
- Lacing Test
- Head Retention Test



Let's review each technique.

Sheeting Test:

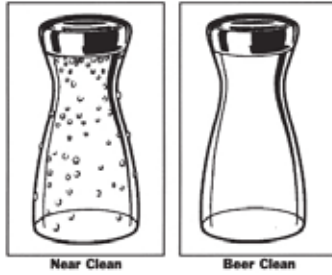

Dip the glass in the rinse water. If the glass is clean, water evenly coats the glass when lifted out of the water. If the glass is not beer clean, water will break up into droplets on both the inside and outside surface.

Salt Test:

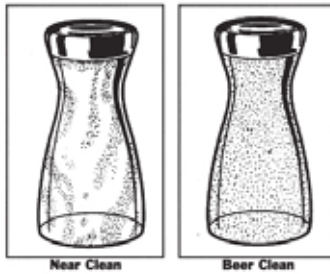

Salt sprinkled on the interior of a wet glass will adhere evenly to the clean surface, but will not adhere to the parts that still contain a greasy film. Poorly cleaned glasses show an uneven distribution of salt.

Lacing Test:



Fill the glass with beer. If the glass is clean, foam will adhere to the inside of the glass in parallel rings after each sip, forming a lacing pattern. If not properly cleaned, foam will adhere in a random pattern, or may not adhere at all.

Head Retention Test:



Pour a beer and the head should stay on the beer. If large coarse bubbles appear around the glass edge and break the head down, this is an indication of a non-beer-clean glass.

The Care, Handling and Storage of Beer Clean Glasses

To keep glassware clean and odor-free after washing do the following:

Dry the Glassware

- 1) Air-dry glassware on a corrugated plastic or stainless steel surface. Drying glasses on a towel or with a towel can leave lint and may transmit germs and odors.
- 2) Do not dry on a non corrugated drain pad or other smooth surface, as they can transfer odors to the glass and slow the drying process.

Glassware Storage

- 1) Store air-dried glassware in plastic (Fig. 12.6) or stainless steel wire baskets to provide maximum air circulation. Similar deeply corrugated baskets, plastic non-odor mesh mats, or surfaces also work.
- 1) Store glassware in an area free of odors, smoke, grease or dust.
- 2) Store chilled glasses in a separate refrigerator away from food products such as meat, fish, cheese or onions as they can impart an odor to the glasses.
- 3) Store beer glasses dry in a chiller. Chill glasses at 36° to 40°F.
- 4) Store beer glasses dry in a freezer. Never use a freezer if glasses are still wet.



(Fig. 12.6)



Beer and Glassware Serving Temperature

Serving beer at between 38° to 44°F delivers the best taste experience for most beer styles.

Beer served at near-frozen temperatures retains more CO₂ gas and can:

1. Result in a more filling experience for the consumer because the CO₂ is released in the stomach and not the glass.
 2. Blind the taste experience, i.e., the beer has a slightly blander taste experience in comparison with beer served at recommended temperatures.
- Domestic lager beer can be enjoyed at 38° to 40°F and poured in a room temperature or chilled glass.
 - Craft beer is ideal for room temperature glasses and can be served in chilled glasses.

Proper Draught Beer Pouring Techniques

Importance of One-inch Foam Collar/Head:

While retailers struggle with customers who demand their beer “filled to the rim,” brewers prefer beer poured with about a one-inch collar of foam (“head”).

- A 1-in. head maximizes retailer profit, as foam is 25% beer. Filling the glass to the rim is really over pouring.
- A proper head on a draught beer delivers the total sensory experience, including the following sensory benefits:
 - Has the visual appeal of a good pour
 - Aromatic volatiles in beer are released
 - Palate-cleansing effect of carbonation is enhanced
 - The textural and sensorial qualities of beer are presented to the consumer

Using the proper serving techniques of draught beer is intended to have a “controlled” release of the carbonation in the beer to give a better tasting and sensory experience. The release of some of the CO₂ gas during pouring builds the foam head and releases desirable flavors and aromas of the beer.

Pouring Technique for a Chilled or Room Temperature Glass

- 1) Hold the glass at 45° angle about ½ in. to 1 in. below the mouth of the faucet.
- 2) Do not grab the top of the tap knob to pour a beer. Place your fingers at the bottom backside of the tap knob and your thumb on the front side of the bottom of the tap knob.
- 3) Now pull the faucet quickly (not hard) and fully towards you and let the beer begin to flow to the bottom of the glass. Partially opening the faucet may cause inefficiency and poor quality, namely:
 - a) Turbulent flow
 - b) Excessive foaming
 - c) Waste (inefficiency)
- 4) As the beer level in the glass rises, gradually tilt glass upright once beer has reached about the halfway point in the glass.
- 5) Continue to pour the beer straight down into the glass. Build approximately a one inch collar of foam (“head”) on the beer by working i.e. lowering the glass to build a larger head or raising the glass to reduce the amount of head on the beer. This gives the beer a great visual appeal, releases some of the carbonation which in turn release the flavor and aroma of the beer.
- 6) When the top of the foam rises to the top of the glass close the faucet by quickly pushing it away from you to avoid wasteful overflow.

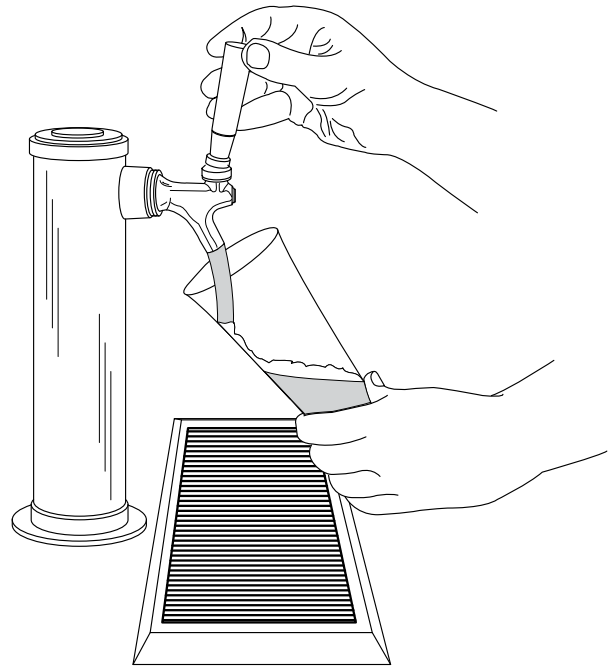

Pouring Techniques for Frozen Glassware

Try one of the following procedures to help you control the foaming problems that are common when using frosted glassware.

Pouring Technique 1 for Frozen Glassware

Pouring beer into a frozen mug can be challenging for the frozen moisture that collects on the glass creates a very rough surface for the beer to flow down. This rough surface causes excessive amount of CO₂ out of the beer and can create a foaming problem.

- 1) Hold the glass at 45° angle about ¼ of an inch below the mouth of the faucet.
- 2) Place your fingers at the bottom backside of the tap knob and your thumb on the front side of the bottom of the tap knob.
- 3) Now open and close the faucet as fast as you can by pulling the faucet quickly (not hard) and fully towards you and then pushing the faucet quickly away from you. This creates a path in the glass where the ice in the glass melts and makes as smooth surface for the beer to flow down.
- 4) Once the foam created in the glass subsides, place the glass at a 45° angle about 1/4 of an inch below the mouth of the faucet.
- 5) Do not grab the top of the tap knob to pour a beer. Place your fingers at the bottom backside of the tap knob and your thumb on the front side of the bottom of the tap knob.
- 6) Now pull the faucet quickly (not hard) and fully towards you and let the beer begin to flow down the smooth path on the inside of the glass that you created in step 3.
- 7) As the beer level in the glass rises, gradually tilt glass upright as the beer reaches the top of the glass.
- 8) When the top of the foam rises to the top of the glass close the faucet by quickly pushing it away from you to avoid wasteful overflow.

Pouring Techniques 2, 3 and 4 for Frozen Glassware

Prior to pouring the beer do one of the following:

- a) Technique 2 – Use the water button on the soda gun and run a quick shot of water down the inside of the glass to make a smooth path in the glass. Then pour the water back out of the glass down the same smooth path.
- b) Technique 3 – Place the glass under the water running, from the water faucet, into the rinse tank to create a smooth path down the inside of the glass. Then pour the water back out of the glass down the same smooth path.
- c) Technique 4 - Water mist devices may be used to pre-wet the glass interior prior to dispense. Purge the water in any glass interior so it does not dilute the beer.

Hold the glass at a 45° angle about ¼ in. below the mouth of the faucet. Now follow steps 5 to 8 above to pour the beer.

Pouring Technique 5 for Frozen Glassware

It may be necessary to add more systems resistance to the system to slow the beer down when pouring into frosted glassware. This will slow down the flow rate and help to reduce excessive foaming. It is recommended that you add at least 2 additional feet of 3/16" ID vinyl beer choker line to the system to slow it down sufficiently to pour beer into a frosted glass.

Once the extra systems resistance has been added to the system use any one the four pouring techniques listed above to pour the beer into the frosted glass.



Pouring Hygiene

In no instance should the faucet nozzle touch the inside of the glass

This can potentially transfer germs from one glass (person) to another.

In no instance should the faucet nozzle become immersed in the beer.

Faucet nozzles dipped in beer become a breeding ground for microorganisms.

For notes on proper dispense hygiene when using a cask ale “beer engine,” see Appendix D.





Section 13

Appendix



13



Appendix A

ISBT Guidelines for Beverage Grade Carbon Dioxide

| | |
|---|--------------------------|
| Purity | 99.9% min* |
| Moisture | 20.0 ppm max |
| Oxygen | 30.0 ppm max |
| Carbon monoxide | 10.0 ppm max |
| Ammonia | 2.5 ppm max |
| Nitric oxide/nitrogen dioxide | 2.5 ppm max each |
| Nonvolatile residue | 10.0 ppm (wt) max |
| Nonvolatile organic residue | 5.0 ppm (wt) max |
| Phosphine | 0.3 ppm max |
| Total volatile hydrocarbons | 50.0 ppm max |
| Acetaldehyde | 0.2 ppm max |
| Aromatic hydrocarbon | 20.0 ppb max |
| Total sulfur content | 0.1 ppm max |
| Sulfur dioxide | 1.0 ppm max |
| Odor of Solid CO ₂ | No foreign odor |
| Appearance in water | No color or turbidity |
| Odor and taste in water | No foreign taste or odor |

All specifications are to be based on volume (v/v) unless otherwise noted.



Appendix B

CO₂ Gauge Pressure Reference Chart

Determination of CO₂ Applied Gauge Pressure Given Volumes of CO₂ and Temperature*

| Vol. CO ₂ | 2.1 | 2.2 | 2.3 | 2.4 | 2.5 | 2.6 | 2.7 | 2.8 | 2.9 | 3.0 | 3.1 |
|----------------------|------|------|------|------|------|------|------|------|------|------|------|
| Temp. °F | psig | psig | psig | psig | psig | psig | psig | psig | psig | psig | psig |
| 33 | 5.0 | 6.0 | 6.9 | 7.9 | 8.8 | 9.8 | 10.7 | 11.7 | 12.6 | 13.6 | 14.5 |
| 34 | 5.2 | 6.2 | 7.2 | 8.1 | 9.1 | 10.1 | 11.1 | 12.0 | 13.0 | 14.0 | 15.0 |
| 35 | 5.6 | 6.6 | 7.6 | 8.6 | 9.7 | 10.7 | 11.7 | 12.7 | 13.7 | 14.8 | 15.8 |
| 36 | 6.1 | 7.1 | 8.2 | 9.2 | 10.2 | 11.3 | 12.3 | 13.4 | 14.4 | 15.5 | 16.5 |
| 37 | 6.6 | 7.6 | 8.7 | 9.8 | 10.8 | 11.9 | 12.9 | 14.0 | 15.1 | 16.1 | 17.2 |
| 38 | 7.0 | 8.1 | 9.2 | 10.3 | 11.3 | 12.4 | 13.5 | 14.5 | 15.6 | 16.7 | 17.8 |
| 39 | 7.6 | 8.7 | 9.8 | 10.8 | 11.9 | 13.0 | 14.1 | 15.2 | 16.3 | 17.4 | 18.5 |
| 40 | 8.0 | 9.1 | 10.2 | 11.3 | 12.4 | 13.5 | 14.6 | 15.7 | 16.8 | 17.9 | 19.0 |
| 41 | 8.3 | 9.4 | 10.6 | 11.7 | 12.8 | 13.9 | 15.1 | 16.2 | 17.3 | 18.4 | 19.5 |
| 42 | 8.8 | 9.9 | 11.0 | 12.2 | 13.3 | 14.4 | 15.6 | 16.7 | 17.8 | 19.0 | 20.1 |

* Chart assumes sea level as altitude. Add 1 psi for every 2,000 ft. above sea level.

Chart Reference

• Based on Data from *Methods of Analysis*, American Society of Brewing Chemists, 5th Edition – 1949
Below:

The correlation of pressure versus volumes of CO₂ at a given temperature is linear

• $y = mx + b$ was used to determine the pressure at a known temperature and CO₂ volume

Example:

At 33°F and 2.6 volumes of CO₂ the line slope is 9.54 and the y-intercept is -15.034, thus

y (CO₂ pressure) = m (slope) x (CO₂ volumes) + b (y – intercept)

$y = 9.54 * 2.6 \text{ volumes} + (-15.034)$

$y = 9.8 \text{ psi CO}_2 \text{ pressure}$

Figuring ideal gauge pressure of straight CO₂ when carbonation level is not known:

1. Set the regulator pressure to 5 psi.
2. Tap a fresh keg. Make sure the keg has been in the cooler long enough to be at the cooler temperature.
3. Pour a small amount of beer through the faucet.
4. Observe the beer in the draught line directly above the keg coupler (with a flashlight if necessary), inspecting for bubbles rising up from the beer in the keg.
5. If bubbles are present, raise the regulator pressure 1 psi.
6. Repeat steps 3 to 5 until no bubbles are present.

This is the lowest pressure at which the gas in the beer is not escaping.



Appendix C

Figuring gauge pressure or blend percentage of CO₂ / N blend

* Mathematical analysis

$$a = \frac{(b + 14.7)}{c} - 14.7$$

$$a + 14.7 = \frac{(b + 14.7)}{c}$$

$$(a + 14.7) * c = b + 14.7$$

$$((a + 14.7) * c) - 14.7 = b$$

$$(a + 14.7) * c = b + 14.7$$

$$c = \frac{(b + 14.7)}{(a + 14.7)}$$

a = psi of the gas

b = ideal gauge pressure of straight

c = % of CO₂ in the gas

To figure the correct keg pressure for a custom CO₂ / N blend, use the following procedure:

You must first know the average carbonation level, in volumes, of the beers you are balancing.

You must know the CO₂ percentage in the blend to be used.

- (1) Using the average carbonation level, figure the ideal gauge pressure of straight CO₂ from the chart in the CO₂ – Figuring the correct pressure section.
- (2) Use the following equation, where
 - (a) a = psi of the gas blend
 - (b) b = ideal gauge pressure with straight CO₂
 - (c) c = % of CO₂ in the gas blend (as a whole number; i.e., 60% CO₂ = 0.6)

$$a = \frac{(b + 14.7)}{c} - 14.7$$

Examples: $a = \frac{(b + 14.7)}{c} - 14.7$

$$a = \frac{(12 + 14.7)}{0.7} - 14.7$$

$$a = \frac{(26.7)}{0.7} - 14.7$$

$$a = (38.1) - 14.7$$

$$a = (23.4)$$

a = psi of the gas

b = 12 straight

c = 70% in the gas



To figure the correct blend for a custom CO₂ / N blend, use the following procedure:

You must first know the average carbonation level, in volumes, of the beers you are balancing.

You must know the operating pressure at which the kegs will be poured.

- (1) Using the average carbonation level, figure the ideal gauge pressure of straight CO₂ from the chart in the CO₂ – Figuring the correct pressure section.
- (2) Use the following equation, where
 - (a) a = psi of the gas blend
 - (b) b = ideal gauge pressure with straight CO₂
 - (c) c = % of CO₂ in the gas blend (as a whole number; i.e., 60% CO₂ = 0.6)

$$c = \frac{(b + 14.7)}{(a + 14.7)}$$

Examples: $c = \frac{(b + 14.7)}{(a + 14.7)}$

$$c = \frac{(12 + 14.7)}{(22 + 14.7)}$$

$$c = \frac{26.7}{6.7}$$

$$c = 0.728 = 72.8\%$$

a = psi of the gas

b = 12 straight

c = 70% in the gas



Appendix D

Notes on Serving Cask Ale

Beer Engines

Beer engines (*Fig 13.1*) dispense cask beer. Pulling the handle actuates a piston or chamber of the engine and pumping beer from the cask to the customer's glass. Beer engines can be clamp-on or built into a bar. Some breweries that make cask ales will require a sparkler (perforated disk) that attaches to the end of pouring spout.



Fig. 13.1

Pouring Hygiene for Cask Ale

Pouring cask ale from a swan neck beer engine faucet is the only instance when the faucet should come into contact with the inside of a beer glass. Due to the unique nature of this beer dispense system, a list of guidelines must be followed to ensure proper sanitation.

- 1) Always use a clean glass when pulling beer from the cask pump. This is the case when pouring any draught beer; however, even more important with cask ale, due to the potential to transfer germs from one glass to another.
 - 2) After the beer is pumped into the clean glass, wipe the entire faucet with a clean towel wetted with fresh water. It is important not to use chemicals as those chemicals may end up in the subsequent beer. It is equally important not to use a rag previously used for wiping bar surfaces or other cleaned areas as those germs may contaminate the next beer as well. Keeping the cask faucet clean and dry is the best defense from potentially contaminating future glasses of cask ale.
 - 3) The closing bartender should do one final clean of the cask faucet, the drip tray and the surface of the entire cask pump when the bar closes. This cleaning should be done with restaurant/bar sanitizer approved by your local and state health code. If the cask faucet uses a sparkler, the sparkler should be removed and soaked overnight in the same sanitizer at a soaking concentration listed by the manufacturer.
 - 4) The opening bartender should wipe the cask faucet with a clean towel wetted with fresh water before the first cask beer is pulled to ensure any residual sanitizer from the previous night is removed. If the cask pump is fitted with a sparkler, thoroughly rinse the sparkler under fresh water before attaching it to the cask faucet.
- Importance of 1-in. collar of foam: Well prepared cask ale will easily allow for 1-in. of head or more if a sparkler is fitted on the end of the faucet. Without the sparkler device, a full 1-in. collar of foam may be difficult to achieve. The bar or restaurant manager should consult the brewer to discuss how their particular beer is intended to be served.
 - The purpose of a proper head on any cask ale is the same as a draught beer; the head helps to deliver the total sensory experience, including the following sensory benefits:
 - a) Visual appeal of a good pour
 - b) Aromatic volatiles in a beer are released
 - c) Palate-cleansing effect of carbonation is enhanced Textural and sensorial qualities of beer are better presented to consumer.



Appendix E
Absolute Pressure

The Absolute Pressure at which the beer is packaged by the brewer

Each brewer packages its draught beer at a certain internal keg pressure to preserve its brewery fresh flavor. Brewers measure beer carbonation in volumes of CO₂. A typical value might be 2.5 volumes of CO₂ meaning, literally, that 2.5 keg’s worth of uncompressed CO₂ has been squeezed/dissolved into one keg of beer.

Each brewer determines the volumes of CO₂ they want in each brand of beer, for it influences the overall character and taste of the draught beer. The more volumes of CO₂ in a keg, the higher the applied gauge pressure on the beer. Carbonation levels in typical beers run from 2.2 to 2.8 volumes of CO₂, but values can range from as little as 1.2 to as high as 4.0 in specialty beers.

Say the draught beer is packed at 2.5 volumes of CO₂ at sea level at 34° F. This would give us a pressure of 9.1 pounds. This is the gauge pressure:

Gauge Pressure:

This then is the pressure that is built into the beer.

Atmospheric Pressure

At the same time, believe it or not, the weight of the air from above the keg to the height of the earth’s atmosphere also exerts a pressure on the keg. This additional pressure is called the atmospheric pressure. At sea level the air above a keg exerts an additional 14.7 lbs per sq. in. on the keg.

Absolute Pressure

Thus, if we add the gauge pressure of the above beer, which was 9.1 psig at sea level (for the keg at a temperature of 34°F and with 2.5 volumes of CO₂) plus the atmospheric pressure of 14.7 psi at sea level, this give us the total or absolute pressure on the beer of 23.8 psi.

Gauge Pressure + Atmospheric Pressure = Absolute Pressure

| | |
|----------------------|-------------------|
| Gauge Pressure | 9.1 psig |
| Atmospheric Pressure | <u>+14.7 psi.</u> |
| Absolute Pressure | 23.8 psi. |

Once this draught beer is packaged in its sealed keg the absolute pressure in the keg remains the same at 23.8 psi as the carbonation level of the beer doesn’t change.

1) The altitude of the retail account in which the beer is being served

The gauge pressure is affected by the altitude at which the retail account is located. As you go up in elevation there is less air above the keg; thus the atmospheric pressure is less.

As it turns out for every 2,000 ft. you go up in elevation, the atmospheric pressure drops by approximately 1 lb. per sq. in. Again this is because there is less air above the keg as you go up in elevation. (See Elevation Chart below)

| Elevation Chart | | | | | | | | |
|--|---|-------------------------------|-----------------------------------|-----------------------------------|-----------------------------------|------------------------------------|-------------------------------------|-------------------------------------|
| Brewers gauge pressure at sea level at 38° F | Gauge pressure at the elevation at which the beer is being served | | | | | | | |
| | -2,000 to -1 ft below sea level | 1 to 2,000 ft above sea level | 2,001 to 4,000 ft above sea level | 4,001 to 6,000 ft above sea level | 6,001 to 8,000 ft above sea level | 8,001 to 10,000 ft above sea level | 10,001 to 12,000 ft above sea level | 12,001 to 14,000 ft above sea level |
| | 10 | 9 | 10 | 11 | 12 | 13 | 14 | 15 |
| 11 | 10 | 11 | 12 | 13 | 14 | 15 | 16 | 17 |
| 12 | 11 | 12 | 13 | 14 | 15 | 16 | 17 | 18 |
| 13 | 12 | 13 | 14 | 15 | 16 | 17 | 18 | 19 |
| 14 | 13 | 14 | 15 | 16 | 17 | 18 | 19 | 20 |
| 15 | 14 | 15 | 16 | 17 | 18 | 19 | 20 | 21 |
| 16 | 15 | 16 | 17 | 18 | 19 | 20 | 21 | 22 |

Knowing that the absolute pressure of the keg remains the same, then for every 2,000 feet that we go up in elevation, (the atmospheric pressure drops 1 lb.) the gauge pressure will go up 1 lb. correspondingly.



True Definition of Gauge Pressure

The gauge pressure is really reading the difference between the absolute pressure, as measured when the beer is packaged, and atmospheric pressure on the keg.

If we took a keg from this brewery to a ski area in Colorado with an elevation of 10,000 ft. above sea level, the atmospheric pressure would be approximately 5 lbs. less than at sea level.

This is because for every 2,000 ft. we go above sea level the atmospheric pressure drops 1 psi. Thus, if we go up 10,000 feet in elevation, the atmospheric pressure will drop 5 psi and then the gauge pressure would go up 5 lbs.

Contact your brewery to see what the gauge pressure of their packed kegs is at sea level. You can then calculate the appropriate gauge pressure you should apply to their keg in your market at your elevation using the chart above.

The temperature of the beer

The temperature of the beer also affects the pressure at which the beer should be drawn.

As it turns out for every 2°F that the beer temperature goes up or down, the gauge pressure will also go up or down by 1 lb.

| Temperature Chart | | | | | | |
|--|-----------------|-----------------|-----------------|-----------------|-----------------|-----------------|
| Determine the appropriate gauge pressure for the system from the chart above; then adjust the gauge pressure by the following amount based on the temperature of the beer in the keg | | | | | | |
| 29-30 Degrees F | 31-32 Degrees F | 33-34 Degrees F | 35-36 Degrees F | 37-38 Degrees F | 39-40 Degrees F | 41-42 Degrees F |
| -4 | -3 | -2 | -1 | 0 | 1 | 2 |

Example:

A brewer's beer is packaged at 15 psig at sea level. The keg is then shipped to a ski area at 10,000 ft. above sea level with a keg temperature of 34° F.

To find the proper gauge pressure to the keg, first go to the Elevation Chart above and find 15 psig in the left hand column. Then move across to the 8,001 to 10,000 ft. Elevation column and you will see the gauge pressure at 38° F should be 20 psig.

Now to adjust the final gauge pressure using the temperature chart above as follows: Go to the 33° to 34° F column to see that you need to adjust the final gauge pressure down 2° or to 18 psig for this account.



Appendix F

CO₂ Tank Pressure

Temperature – Pressure Relationships of Carbon Dioxide at Various Densities

| Temperature – Pressure Relationships of Carbon Dioxide at Various Filling Densities | | | | | | | |
|---|---------|------|------|------|------|------|------|
| Percent of Cylinder (Water Weight Capacity) | | | | | | | |
| Temperature °F. | Correct | | | | | | |
| | 68% | 75% | 80% | 85% | 90% | 95% | 100% |
| 60 | 747 | 747 | 747 | 1020 | 1595 | 2590 | |
| 70 | 852 | 852 | 1060 | 1445 | 2120 | | |
| 80 | 975 | 1145 | 1145 | 1895 | 2675 | | |
| 90 | 1205 | 1460 | 1795 | 2345 | | | |
| 100 | 1465 | 1785 | 2185 | | | | |
| 110 | 1725 | 2110 | 2575 | | | | |
| 120 | 1995 | 2450 | | | | | |
| 130 | 2265 | 2790 | | | | | |
| 140 | 2545 | | | | | | |
| 150 | | | | | | | |

A correctly installed carbon dioxide cylinder's rupture disc blows at 2,800 to 3,000 pounds depending on design.

NOTE: This chart is based upon a cylinder filled to its correct maximum liquid carbon dioxide capacity of 68% of the total volume (water weight capacity). An overfilled cylinder will obviously experience enormous internal pressures from expansion of the liquid at higher temperatures after filling.

Source: Carbon Dioxide Cylinder Filling and Handling Procedures for Beverage Plants

Sponsored by
National Soft Drink Association
Compressed Gas Association



Appendix G

How to Calibrate an Adjustable Dial Thermometer

To ensure your thermometer is accurate, calibrate it using the following procedure:

- 1) Fill a large beer glass with shaved or crushed ice. Then fill it up with cold water out of the water faucet.
- 2) Remove the thermometer from its case and drop it into the ice water.
- 3) Now stir the ice water with the thermometer for about one minute. The needle should now point (approximately) to 32°F.

If the thermometer is not reading 32°F, adjust it as follows.

- 1) While leaving the thermometer suspended in the ice water, grip the face of the thermometer with a pair of pliers.
- 2) Next place a 3/8 in. open ended wrench on the nut on the underside of the thermometer.
- 3) Now, using the pliers turn the face of the thermometer clockwise or counterclockwise until the needle points at 32°F.
- 4) Your thermometer is now calibrated. You should do this at each stop to make sure you get an accurate reading each time you use your dial thermometer to test the temperature of the beer.





Section 14

Glossary



14



Glossary

Acid cleaner

Although several blends of acid cleaners are recommended to assist in beer stone and water stone removal, some acids react with system components. Phosphoric acid-based blends are the only ones safe on all materials.

Balance

Ensuring that the applied pressure matches the system requirements so that the beer dispenses at the optimum rate of about 2 oz. per second or 1 gallon per minute while maintaining brewery specified carbonation level.

Barrier Tubing

A plastic tubing, with a lining of nylon or PET that provides a gas barrier to better protect the beer from oxidation.

Beer Pump

A mechanical pump that is generally driven by compressed air or CO₂ that can move beer great distances without changing the dissolved gases.

Beer Stone/Calcium Oxalate

Is a mineral deposit that forms slowly on a surface from beer and is very difficult to remove.

Caustic or Caustic Soda or NaOH – Sodium Hydroxide

Is a high pH chemical commonly used in blending draught line cleaning solutions that will react with organic deposits in the draught beer line. It is very effective, but also very dangerous. Commonly used in oven cleaners.

Caustic Potash or KOH or Potassium Hydroxide

Similar to sodium hydroxide, but offers slightly different chemical properties in a blended cleaning solution.

CO₂ – Carbon Dioxide

A natural product of fermentation and the gas used to push beer in draught beer systems. CO₂ leaks in the gas system are dangerous because high concentrations of CO₂ will displace air and cause asphyxiation.

CO₂ Volumes

The concentration of CO₂ in beer expressed as volumes of gas at standard conditions per volume of beer.

Coil Box

A cooling system to bring beer to serving temperature at the point of dispense consisting of a coil of stainless steel immersed in ice water. Often used at picnics or events where normal keg temperature cannot be maintained.

Cold Plate

A cooling system to bring beer to serving temperature at the point of dispense consisting of a stainless steel coil embedded in an aluminum plate in contact with the ice. Cooling is the result of melting the ice rather than just heat transfer, so water must be drained away from the cold plate. Often used at picnics or events where normal keg temperature cannot be maintained.

Coupler

The connector to the keg.

Dewar

An insulated, pressurized container for liquefied gas such as CO₂.

Direct Draw

A draught beer system that has a short jumper connection from the keg to the faucet.

EDTA – Ethylene Diamine Tetracetic Acid

A cleaning solution additive that can dissolve calcium mineral deposits in draught beer systems.

Faucet

The dispensing end of the draught beer system that controls the flow of beer.

Flash Chillers

Mechanical cooling systems to bring beer to serving temperature at the point of dispense. Often used with flash-pasteurized kegs that can be stored at room temperature.

FOB – Foam on Beer Detector

A device that stops the flow of beer when the keg is empty before the beer line is filled with foam.

Glycol or Propylene Glycol

A food-grade refrigerant that is recirculated through insulated tubing bundles to maintain beer temperature.

ISBT

International Society of Beverage Technologists who created a quality standard for CO₂ for beverage use.

Jockey Box

A cooler with a coiling coil or cold plate and faucets to chill the beer at the point of dispense.

Jumper Line/Tubing

The flexible piece of vinyl tubing that is used between the keg and draught beer system that should be replaced annually.

Lift

The change in height from the keg to the faucet that is a component of system balance.



Line

Tubing that makes up the draught beer flow path.

Long Draw

A draught beer system over 50 feet long that uses barrier tubing in a refrigerated bundle that typically requires a mixed gas to avoid over-carbonation.

Nitrogen Generator

A system designed to separate nitrogen from compressed air, typically by membrane. Nitrogen used for beer dispense in a mixed gas application must be >99% pure.

NSF – National Sanitation Foundation

An organization that certifies food service equipment for performance and cleanability.

Party Pump or Picnic Pump

A hand pump that uses compressed air to dispense beer. This type of pump should only be used when the entire keg is going to be dispensed at one time because oxygen will damage the beer.

PE – Polyethylene

Stiffer tubing used in older refrigerated bundles. This oxygen-permeable material contributed to oxidation of the beer remaining in the lines and is now only recommended for use as glycol tubing.

Pot – Pressure Pot, Cleaning Pot

A canister for cleaning solution or rinse water that is connected to a pressure source pushing the solution through the lines like beer. Does not give sufficient velocity for (mechanical) cleaning, so this should only be used on short lines with longer chemical exposure.

PSI

Pounds per square inch - a unit of measure of gas pressure.

PSIA – Pounds per Square Inch Absolute

A measure of gas pressure against a perfect vacuum so it includes the atmospheric pressure of 14.7 psi at sea level.

PSIG – Pounds per Square Inch Gauge

A measure of gas pressure against the atmospheric pressure, typically seen on gas regulator gauges. Since atmospheric pressure varies with altitude, the gauge pressure must be adjusted with altitude.

PVC – Polyvinyl Chloride

Flexible jumper tubing.

Regulator

A gas control valve that delivers a set gas pressure regardless of tank pressure. There may be a primary regulator on the gas source and a secondary regulator at the gas connection for each keg.

Resistance (or System/Component/Line Resistance)

A measure of the pressure drop across a component or over a length of tubing at the optimum beer flow rate.

Sanitizer

An EPA-registered product that is designed to kill microorganisms.

Sankey

This term refers to the modern style of keg coupler. It is available in several versions to fit specific styles of keg valves produced in Europe and the USA.

Sequestrants

Chemicals that hold metal ions in solution and prevent mineral deposits.

Series Kegs

Hooking multiple kegs together so the beer from the first flows through the second and then into the next so that the kegs can be changed less frequently.

Shank

The connecting piece that goes through the cold box wall or tower and connects the tubing and tail piece to the tap. It also can help provide system pressure reduction.

Short Draw

A draught system under 25 ft. long that can be run on straight CO₂ or mixed gas, and can use air-cooled or refrigerated lines.

Surfactants

Compounds used in blended draught beer line cleaners that lower surface tension to enhance surface wetting, break the bond between deposits and the tubing surface and suspend soils in cleaning solution so they can be removed.

Tail Pieces

The connectors that allow a piece of tubing to be attached to a piece of equipment.

Tap

The connector from the draught system to the keg (more properly referred to as a coupler).

Tower

The mount on the bar that holds the faucets and is cooled to maintain beer temperature up to the point of dispense.

Water Conditioners

A component of a blended cleaner that is intended to carry away soils.

Water Stone – Calcium Carbonate

A mineral deposit that forms from water that can be removed with acid.





BEER FAUCETS

KEG COUPLERS

TUBING

FITTINGS

AIR/GAS DISTRIBUTION EQUIPMENT

REGULATORS

SHANKS

BEER PUMP PANEL

TEST COUPLERS

DISPENSING HEAD

BREWERY FITTING

DRIP PANS

PARTY PUMPS

CLEANING KITS

BRAND ID BADGES



You're just a few clicks away from the industry's best tapping equipment

Perlick has always been known for its high quality, american-made tapping parts. Now, with the all new perlick.com, you can get information on tapping parts and conveniently place your online order via Shop Perlick. Whether it's a keg coupler, beer line cleaning solution or a dispensing head, you'll be sure to find it with ease like never before.

Visit perlick.com/store to order today!



Perlick®

QUALITY & INNOVATION
THAT **INSPIRES**

8300 West Good Hope Road
Milwaukee, Wisconsin 53223

perlick.com • 800.558.5592